

# Understanding the Future Workplace

Research towards the use of organisational characteristics in the transition to the hybrid workplace

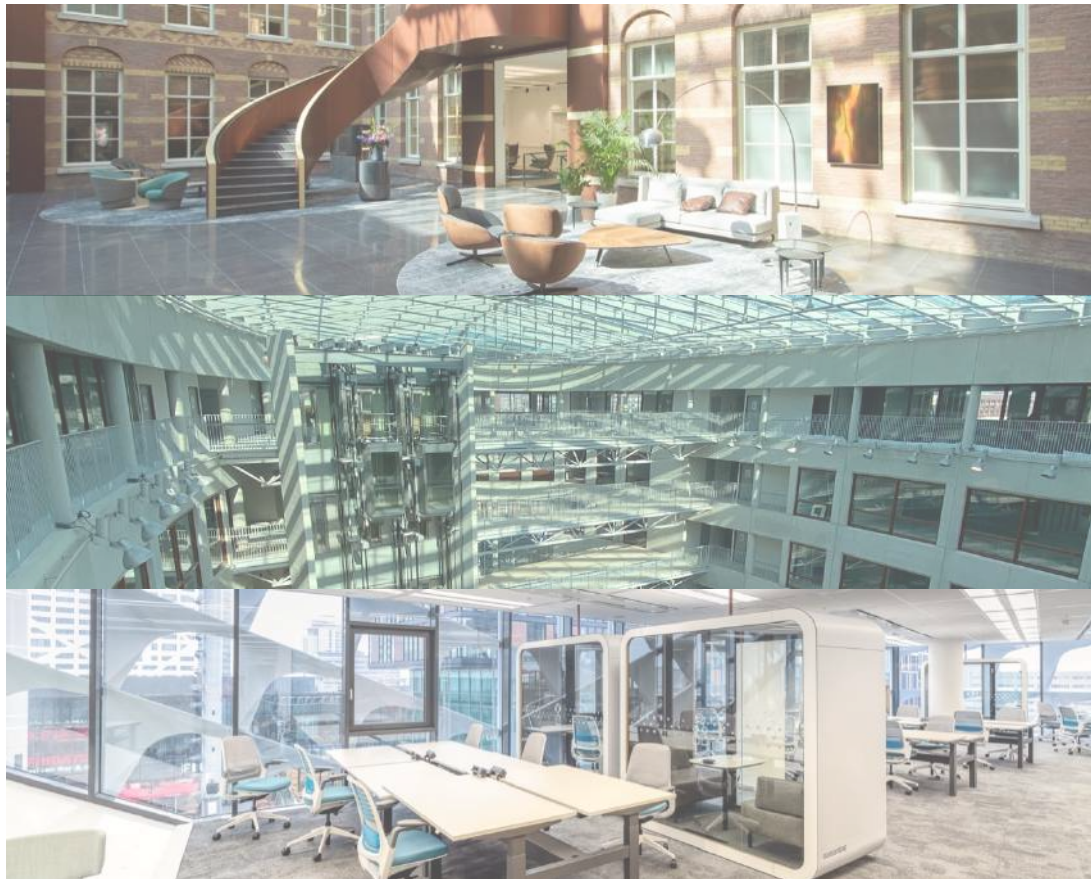

Thesis Report

MSc Management in the Built Environment  
Technical University of Delft

Oscar Leonard Nowak

# Colophon



---

Name: Oscar Leonard Nowak  
Student number: 4489454  
Email: o.l.nowak@student.tudelft.nl | oscarnowak97@gmail.com  
Mobile number: +31627552763  
Address: Bergweg 264A, 3035BS Rotterdam

---

University: Technical University of Delft  
Faculty: Faculty of Architecture  
Track: MSc Management in the Built Environment

First mentor: Ir. H.J.M. Vande Putte  
Second mentor: Dr. A. Thomas  
Delegate board examiners: Dr. A. Kockelkorn

---

Graduation organisation: Dev\_ real estate  
Mentor: Ir. B. Rodenburg

Version: P5 Report  
Date: 23/06/2022

# Foreword

During my period as a student, I have constantly explored what interests me. It started with a bachelor's in civil engineering, from which I quickly switched to architecture. Then, after graduating in 2020, I decided to pursue the track Management in the Built Environment as a master. This was a tough choice, as I am still passionate about architecture and design. Therefore, I have been seeking opportunities to combine the practices of management and architecture. Over the past months, I have realised I might find this combination in the field of real estate management. This inspired me to choose this field of research as my thesis theme.

During my thesis, my graduation organisation granted me the opportunity to explore the field of real estate management first-hand. This gave me useful, practical insights for my research and what might fit me best as a future career path.

Along the way, I conducted, analysed, and wrote this research. It was an enjoyable and informative experience to collect data, opinions, and experiences from many different people and perspectives. Whilst reading this document, I hope you too will find it, in one way or another, as enjoyable as I did.

# Acknowledgements

I would like to thank a few people who made this process possible and enjoyable. Firstly, many thanks to my first mentor Herman Vande Putte. His guidance helped and inspired me to find a subject that I am passionate about. I would like to thank my second mentor Amy Thomas for providing me with important insights along the way. I learned a lot from our discussions and your perspective.

I would like to give special thanks to my graduation mentor Bart Rodenburg. He guided me continuously through the second half of my research. He was always open to questions or a good discussion. Bart always knew the right question to fire back at my question so I would come up with the answer myself. Looking back at the past months, this guidance brought my understanding and my process to a higher level.

Furthermore, I like to thank the other employees of Dev\_ real estate for being open and interested and granting me a very insightful internship.

Finally, I would like to express my gratitude to all professionals who participated in my interviews.

It goes without saying that I deeply appreciate the support and encouragement I have received from my close friends and family.

# Abstract

## Context

During the worldwide pandemic between 2020 and 2022, lockdowns were instigated. Working from home became the norm for almost two years. This has caused the needs and preferences of employees and employers regarding work and the workplace to change for good.

## Problem

As a result, the common preference for implementing more remote work in the post-pandemic era grew. This combination of remote work and in-office work is named a hybrid strategy. Many services and public sector managers plan to create a hybrid workplace to support these preferences. However, the research toward this post-pandemic office is in its starting blocks. Furthermore, creating a workplace is complex, and no one-size-fits-all solution exists. Managers must find a future workplace that aligns with their organisational beliefs, values, strategy, and assets. How these characteristics are used to transition toward a hybrid workplace remains unclear.

## Purpose

This research aims to understand how organisational characteristics are used to transition to a hybrid workplace. This knowledge can serve as a map for managers planning to initiate a similar transition and as a backbone for further research towards future workplaces.

## Method

A literature study first identifies the organisational characteristics by introducing a corporate real estate assets management model. Then, case studies are performed on implemented hybrid workplaces to collect data on how characteristics are used in a transition. Cases are collected from the client pool of the graduation organisation Dev\_ real estate, a real estate advisor with experience with hybrid workplaces. Three cases are selected based on various selection criteria. The workplace can be seen as a complex issue. Therefore, a qualitative approach is used to analyse the various perspectives and data sources in-depth. Data is collected from semi-structured interviews, exploring the views and experiences of the participants open-endedly. The participants are the architect, the project manager, the organisational manager, and the employee. Other sources are internal reports and floor plans. The data is collected, reduced, and coded based on the model introduced in the literature. A within-case and cross-case analysis are performed to identify the similarities and differences between the cases and literature.

## Findings

The analysis identifies a common sequencing of organisation characteristics used in all cases. The research also concludes that the neglect or ignorance of certain characteristics causes the hybrid workplace to remain unaligned with organisational values after completion. Furthermore, the management model used during this research is critically reviewed and concluded to be incomplete. The addition of a new component is proposed.

# Readers Guide

This research paper is divided into four parts, each containing one or more chapters.

## Part 1: Background

The first part of this research introduces the context, whereafter the research environment is demarcated, and the problem within is presented. The researchers' motives and the objects are described. Finally, the research questions are presented.

## Part 2: Theories & Models

This part can be seen as the foundation of the research. First, a literature study provides further background information defining and clarifying the research environment. This information is used to answer the first research sub-questions. Then, the methodology of the case study research is elaborated, with which the remaining sub-questions and main question are answered.

## Part 3: Findings

The case study data is collected, coded, and reduced. The findings are presented and analysed in individual case study reports. This information is used to answer the sub-questions for the three cases separately.

## Part 4: Synthesis

The separate cases are cross analysed with each other and with literature. The literature is critically reflected as a method for this research and as an instrument for practice. The main conclusion is drawn with the previously gained knowledge, answering the main question. Then, further recommendations are provided. The research is finalised by reflecting on the topic, process, and method.

# Table of Contents

Colophon .....	2
Foreword.....	3
Acknowledgements.....	4
Abstract .....	5
Readers Guide .....	6
Part 1: Background .....	9
1. Introduction .....	10
1.1 The research context.....	10
1.2 Research Objective .....	16
1.3 Research Questions .....	17
1.4 Motives and Relevance .....	18
Part 2: Theories & Models.....	19
2. Literature study.....	20
2.1 Introduction.....	20
2.2 Workplace Alignment .....	21
2.3 The Hybrid Workplace.....	35
3. Methodology.....	38
3.1 Type of study .....	38
3.2 Part 1: Background .....	39
3.3 Part 2: Theories & Models .....	39
3.4 Part 3: Findings .....	40
3.5 Part 4: Synthesis .....	46
3.6 Ethical considerations.....	47
3.7 Summary .....	48
Part 3: Findings .....	49
4. Case Studies .....	50
4.1 Case A: Clifford Chance   Droogbak.....	51
4.2 Case B: Nederlandse Politie   HUB50.....	60
4.3 Case C: VodafoneZiggo   Utrecht Central Office .....	67

Part 4: Synthesis .....	73
5. Cross-case Analysis .....	74
6. Discussion with literature .....	82
6.1 Introduction.....	82
6.2 Findings .....	83
6.3 Discussion.....	100
7. Conclusion .....	104
8. Recommendations .....	107
9. Reflection .....	109
9.1 Topic Reflection .....	109
9.2 Method Reflection .....	110
10. References.....	111
Appendix A: Informed Consent document.....	119
Appendix B: Additional interview information document .....	120

---

# Part 1: Background

# 1. Introduction

## 1.1 The research context

*“Hybrid working is becoming the norm, but what is normal hybrid work?” (Grant, 2022).*

Organisational psychologist Adam Grant recently started his WorkLife podcast with this question. Grant reflects on many large organisations' actions during the Covid pandemic, which led straight into the hybrid work environment without any road signs or directions. “To make hybrid work, we need to draw a map.”

Half of the people in Northern Europe and America cannot work from home. These are jobs in, for instance, retail, manufacturing, hospitals, and the police force. The other half, in theory, can. And according to Nick Bloom, a Stanford economist, specialised in hybrid work since 2004, most of this half will be working hybrid in the near future.

Hybrid work, combining work in the office with remote work and connecting the two with a virtual workplace, is nothing new (Cook et al., 2020). Even before computers, in the 80s, people would receive a large pile of paper on their doorstep to process at home. As organisations tried to keep their employees on short leases, this flexible strategy was less common than now. In 2010, Nick Bloom ran an experiment with a group of randomly picked American employees working at randomly picked organisations. The only criterion was that the participants could, in principle, perform their job at home. The group was then asked to do so full-time. As a result, the average productivity increased by 13 per cent, taking shorter and fewer breaks and being 50 per cent less likely to quit their job (Grant, 2022).

Fast forward ten years, this experiment was forcefully performed worldwide due to the Covid-19 pandemic. Nick Bloom started, once again, extracting working-from-home data from American employees. He found that over 80 per cent of the participants found home working more positive than expected. Also, he concluded that employees typically save 70 minutes per day when working from home, let alone the real estate cost it could save organisations (Grant, 2022).

The pandemic is seen as a realisation moment for employers and employees. Others call it a leap in workplace development. Many large organisations have decided that this ‘future’ concept is the new norm. And it does sound like a win-win situation, right?

Sadly, but not surprisingly, it's not that simple. The hybrid work concept comes with many challenges and, without proper implementation, can cause lower performance than in the pre-pandemic office (Lufkin, 2021).

Workplace development might have taken a 20-year leap, but managerial skills have not. Organisations might realise they want a hybrid workplace, but to the managers ordered to implement this, it remains unclear what it looks like and how to get there. Like every office

environment, there is no magic formula for implementing the hybrid workplace (Warzel & Petersen, 2021). Organisations must find their way, identifying their organisational values, beliefs and assets and aligning these in a future hybrid workplace design.

It is the goal of this research to support the manager on this journey. It uses corporate real estate asset management theory as an instrument to analyse the organisational characteristics and map out how these are used in several recently implemented post-pandemic hybrid workplaces. This research thus views the transitions toward the hybrid workplace from an organisational point of view. The context this research is situated in is further elaborated in this chapter.

### 1.1.1 Changes in needs and preferences

The Covid-19 pandemic has greatly impacted the workplace. Due to lockdowns worldwide, organisations were forced to close their offices and send millions of their workforce home to work remotely (De Klerk et al., 2021). Working from home was nothing new for some, as 1.3 million Dutch employees already used their homes as their workspace in 2019. But it was a great shock for the 5.5 million Dutch workers who had never worked from home (CBS, 2020). Within the first weeks of full-time home working, it soon became apparent that workload, stress, and burnout were increasing (Soebhan, 2020).

At the same time, the corporate management had their head in their hands. Not only would the whole organisation have to communicate differently and manage the day-to-day issues mentioned above, but they would also have to reinvent their complete organisational strategy to fit the home office. Client retention, the law on talent, employee connection and new working condition laws were now some of the many challenges added to the workload of managers, all to be performed remotely.

What happened next came to most as a surprise: instead of the anticipated economic recess and consequences to employees and organisations, remote work slowly but surely outperformed more effectively than expected (JLL, 2020; World Economic Forum, 2021). Dutch organisations can mainly thank themselves for this, as great investments within organisations kept productivity up to the mark. For instance, the possibility to meet online was increased from around 50 per cent to almost 100 per cent, and organisations that offered work-from-home facilities increased from 85 per cent to 96 per cent. Moreover, surveys showed that organisations were not only responding to the current changes but were already planning to integrate working from home into their long-term workplace strategies (Ministerie van Infrastructuur en Waterstaat, 2021).

However, this *pandemic productivity* is not only fun and games. Young talents hired by organisations during the lockdown had not met their team face-to-face in over a year and felt alienated. The 70 minutes employees saved by not having to get ready and the commute was often used to start work earlier, unpaid. In fact, employees spent an extra 30 minutes per day performing job-related tasks (Lafkin, 2021). People worked and studied obsessively. Because, why not? *You were at the office anyway; it was your home* (Warzel & Petersen, 2021). Employees became anxious and scared to lose their job and worked even harder during the insecure

pandemic years. They felt invisible and pressured, but to prove their performance, they worked even longer (Lafkin, 2021).

The research into the effects of remote work is ongoing, but one thing is certain to employees and employers who have worked at home during the lockdown. As the COO of JPMorgan puts it:

*“There is zero per cent chance of returning to the office with all the people, all the time. But there is also zero per cent chance of working from home as we did during the lockdown”*  
(Warzel & Petersen, 2021).

This realisation of the possibilities of home working has changed the needs and preferences in the workplace environment of both employer and employee. Large-scale international surveys during the pandemic show that both employers (PWC, 2020b; JLL, 2020; WillisTowersWatson, 2020; McKinsey & Company, 2021; Fortune, 2020) and employees (Galanti et al., 2021; Vander Elst et al., 2020; Sociaal en Cultureel Planbureau, 2021; WillisTowersWatson, 2020; Fortune, 2020) prefer to see more remote work implemented in their workplace strategy in post-pandemic times than ever before.

These surveys have started identifying these needs, asking employers and employees how many days they prefer to work out of the office in a post-Covid era. They conclude that 72 per cent of Dutch employees want to continue to work remotely on average two times a week, and 38 per cent of employers want their workforce to work from home two or more times a week (JLL, 2020). This is different per sector. For instance, organisations in the financial- and services sector in The Netherlands expect their employees to work from home for 41 per cent of all working hours in the post-Covid era. This is the highest in the country. Governmental organisations come in second place, expecting a 35 per cent home and a 65 per cent office ratio. Construction expects the least homeworking, expecting only 14 per cent of tasks to be performed from home (Centraal Planbureau, 2021).

The unexpected restrictions in the past years have forced us to change how they view work. People underwent a paradigm shift; many had to create a desk out of their dining table, care for kids during zoom calls or graduate from their small student rooms. It was presumed that this would cause a large reduction in efficiency and productivity. However, over two years of home working, the workforce adjusted their life to this change and realised its potential. As lockdowns appear to be over, the dusty offices may welcome back their employees. However, these pre-Covid offices do not support the new preferences of employees and organisations. Recently, researchers and experts have thus begun to guide real estate managers in what their future office workplace could and should look like. Tom Carroll, Head of Corporate Research for Europe at JLL, claims companies will want to use the office workplace to train new staff, solve problems and develop new ideas. The Australian architectural firm Woods Bagot envisions the future office as a place to socialise, replacing desks and screens with comfy chairs and sofas. And Coen van Oostrom, CEO of the real estate company EDGE, predicts the office will be a place to communicate and have fun, as “desk work could be done from anywhere” (Bachhi, 2021).

These scenarios vary. To a real estate manager, it remains unclear how to create a future workplace that supports the preferred hybrid work of the organisation and employee. A 2021 survey shows the magnitude of this issue, as 77% of large-sized organisations do not have a policy in place to support the transition to a hybrid workplace and are therefore hesitant to make this change (WillisTowersWatson, 2020).

### 1.1.2 Workplace flexibility throughout history

So why not just copy from your neighbouring company, or implement one of the strategies above? The answer can be found in the fundamentals of management. Management is the attainment of organisational goals effectively and efficiently through planning, organising, and controlling organisational resources (Daft, 2015). For over a century, management theories and styles have been developing to support the goals of an organisation in its current environment.

One of the first widespread implemented managerial theories was that of Frederick W. Taylor in the early 20th century. Fuelled by the success of the Industrial Revolution, growing organisation size and machinery advancements, Taylor invented the scientific management theory. This management style emphasised profit optimisation by utilising employees through controlled mechanisms and training. Managers using this theory would resolve inefficiencies in their organisation by analysing workers' skills, subdividing tasks, and finding the fitted training method. This division of labour meant that workers would be treated as machines. It was effective initially, but this management style soon received criticism for inhumane working conditions and long-term ineffectiveness (Uddin & Hossain, 2015).

Scientific management and its neglect caused by the utilisation of employees as if they were mechanical objects needed improvement. Over the decades, management styles have developed. Academic research, political changes, economic recessions and growth, wars, and technological advancements are only a few factors that affected the workplace along the way.

For instance, the ground-breaking Hawthorne case studies, conducted between 1932 and 1933, concluding employee productivity increases when their contribution is valued, job security is given, and ranks are eliminated. And thus, behavioural sciences were added to management theory, creating a new style: Modern Management (Uddin & Hossain, 2015).

But then, traumatised by World War II and the Cold War, Northern Europe had enough corporate, hierarchical, and ideological structures. After half a century of Taylor-inspired workplaces, the German Eberhard and Wolfgang Schnelle came up with a close-to-opposite idea. The static, bureaucratic workplace ought to make place for a more egalitarian configuration: the office landscape. This open space workplace consisted of several smaller environments, divided by, for example, plants and furniture. These subdivided areas, fit for a small group, encouraged interaction and collaboration between employees, elements found to be more and more important in the corporate work processes (Meijel, L., & Bouma, T., 2013). The office landscape introduced a form of flexibility within the workplace, which after many iterations, is still used in the future hybrid workplace.

During the economic recession in the 80s, the definition of flexibility changed. Organisations started to use it to brand flexible contracts, allowing employees to manage their time and choose when to work. Organisations used this ‘flexibility’ to easily hire and fire people, transferring their economic insecurity onto the workforce (Warzel & Peterson, 2021).

In the 90s and 00s, the term flexibility took on a new form. Automation, globalisation, the internet, and the mobile phone allowed the workplace to be anywhere in the world. Activity-based working, an office configuration consisting of several working areas in which employees do not have a fixed space, became popular (Meijel, L., & Bouma, T., 2013).

However, it was only during the Covid pandemic that the home fully became the workplace. Every boundary between work and private life evaporated, and the home became the office. The amount of work 18 to 35-year-olds performed from their bed doubled, newly hired employees could not connect personally with colleagues, and the average day was regulated by 30, 60 or 90-minute awkward Zoom meetings. This work environment was not sustainable, and it became clear that the quality of work needed to increase (Warzel & Peterson, 2021).

### 1.1.3 No one size fits all

The importance of employee needs and the quality of the working environment are widely researched topics. For instance, studies show that improving indoor performance improves productivity (Roelofsen, 2002) and the positive impact of the accommodation on performance (Van Ree, 2009). Together with external influences, for instance, globalisation and technological advancements, organisations were expected to meet more and more performance criteria, as seen in figure 1.

<b>till 1950s</b> effective	<b>1960s</b> effective efficient	<b>1970s</b> effective efficient productive	<b>1980s</b> effective efficient productive flexible	<b>1990s</b> effective efficient productive flexible creative
--------------------------------	--	--	--	--

Figure 1: Organisational performance criteria (Van Ree, 2002)

This complexity led to the wicked problem of the workplace: no one-size-fits-all office design could be used that would meet all the needs and preferences of employees and organisations. It also applies to the hybrid strategy. A manager must pursue the optimal workplace by constantly analysing, organising, and controlling a broad set of organisational assets (Appel-Meulenbroek & Danivska, 2021; Haynes et al., 2017). Due to the complexity of organisations, this workplace is unique. Aligning the workplace strategy with the characteristics of an organisation is the focus of corporate real estate management (CREM). Arkesteijn (2019) defines CREM as:

*“The management of a corporation’s real estate portfolio by aligning the portfolio and services to the needs of the core business (processes), to obtain maximum added value for the business and to contribute optimally to the overall performance of the corporation”.*

To support managers in aligning the workplace, Haynes, Nunnington & Eccles published a theoretical model in 2017, further elaborated on in 2.3.1. According to the authors, any organisation can be divided into ten components or '*organisational characteristics*'. A manager's task is to identify each characteristic's use and then use the workplace to align it to the other characteristics. In other words, a unique set of aligned organisational characteristics results in an optimised unique workplace for each organisation.

This brings us back to the issue at hand. The pandemic has forced how we view work, in general, to change rapidly (Gillen, 2021). It has been a catalyst for workplace development and the change in needs and preferences of organisations and employees. Survey research concludes the demand for hybrid working has shot up, with 76 per cent of CEO's indicating their post-pandemic workplace will need less space, driving major cost reductions in operational costs and capital expenditures (Deloitte, 2021; WillisTowersWatson, 2020; Bacchi, 2021). Among employees, 83 per cent want to go hybrid after the pandemic. The pre-pandemic workplace is thus unaligned with the needs of organisations and employees.

Managers need to implement change and know the endpoint: the hybrid strategy. However, it is uncertain how organisations must realign their values, beliefs, and assets to get there. It is unknown if existing workplace models are still accurate in post-covid times. The research problem statement can therefore be defined as:

*It remains unclear to managers how to use the organisational characteristics in the transition to a hybrid workplace.*

## 1.2 Research Objective

Workplace design is a complex challenge with no one-size-fits-all solution (Haynes et al., 2017; Warzel & Petersen, 2021). Fortunately, modern management theory provides theoretical models that can support managers in aligning the workplace to organisational characteristics. However, due to the rapid change in workplace needs and preferences caused by the pandemic, it remains unclear how these organisational characteristics are used in future hybrid workplaces.

To support a large share of large organisations in The Netherlands that do not have a policy in place to implement the preferred hybrid workplace, this research intends to understand how organisational characteristics are used in post-pandemic transitions to a hybrid workplace.

This understanding is formed by meeting the research objectives, which are (1) defining the organisational characteristics, (2) analysing implemented hybrid workplace transitions of knowledge-intensive organisations in the public and services sector and (3) concluding how these organisation characteristics are used in the hybrid workplace.

## 1.3 Research Questions

### 1.3.1 Main Research Question

Chapter 1 describes the research environment and the problem within it. The objective of this research is how organisational characteristics are used in the transition to a post-pandemic hybrid workplace. To define the nature and scope of this output, a research question is set up before research, namely.

*How are organisational characteristics used in the transition to a hybrid workplace?*

### 1.3.2 Research Sub Questions

A broader understanding of the research context is needed to answer this question sufficiently. Therefore, five sub-questions defining and clarifying the research environment are answered first.

Sub question 1: *What are the organisational characteristics, and how are they used in workplace management?*

Sub question 2: *What is the hybrid workplace, and what are its benefits and challenges for the organisation?*

Sub question 3: *With which characteristics can an organisation be described?*

Sub question 4: *How are these characteristics used in the current workplace design?*

Sub question 5: *Based on which organisational characteristics are decisions made in the transition to a hybrid workplace? And how are these reflected in the design solutions?*

## 1.4 Motives and Relevance

Pursuing a problem and performing research often starts with the researcher's motive (Blaikie & Priest, 2019). If the new knowledge created during this research is significant and contributes to the following societal or academic contexts, relevance is achieved.

### 1.4.1 Personal Motive

Choosing the topic of the hybrid work environment was motivated by a personal curiosity to experience topical issues in practice. As a graduate of the Technical University of Delft, almost all learning experiences in the past five years were in an (online) classroom and written down in a notebook. Especially over the past year, the desire to experience and apply this theoretical knowledge in practice grew. Therefore, a topical issue that could connect the theories and models to practice was chosen.

Furthermore, the desire to connect managerial practices and design also motivated this choice of topic. Architectural design is a strong personal interest. However, in the master track Management in the Built Environment, little connection between managerial theories and the physical design of real estate is taught. This does occur in subjects focused on corporate real estate asset management.

### 1.4.2 Societal Relevance

This study also has societal relevance, as many organisations in The Netherlands are currently planning on implementing a hybrid strategy (CBRE, 2021b). How and to what extent this new workplace can and should align with organisational values remains unclear. This research seeks to add knowledge to the field of hybrid workplace implementation to support these organisations.

### 1.4.3 Academic Relevance

As the world emerges from the lockdown, many lives, places, and processes are changed for good, the workplace being one of them. The research on this post-pandemic work culture, workplace development and the changing needs and preferences of the organisation and employer that comes with it are in its starting blocks. Therefore, the field still needs to be explored, and possibilities still need to be experimented on before conclusions can be made. This study attempts to grasp the organisation's fundamental characteristics and find its connection with the hybrid workplace environment. This can form the backbone of further research in the field of post-pandemic hybrid workplaces.

---

## Part 2: Theories & Models

## 2. Literature study

### 2.1 Introduction

This chapter provides an overview of the literature regarding the research context. This information forms the basis for answering the first three sub-questions. This chapter is split up into two segments, each explained below.

#### 1. Workplace alignment

The first literature study zooms in on the workplace. It describes how the external factors can influence the workplace and how internal organisational factors affect the components of the office. This chapter introduces a model published by Haynes, Nunnington & Eccles in 2017 that categorises these internal organisational factors. This information is used to answer the first sub-question, defined as:

*What are the organisational characteristics, and how are they used in workplace management?*

#### 2. The hybrid workplace

The hybrid workplace is often portrayed as a win-win. According to research, the employer, employee, and society (partly) benefit from implementing home working in the workplace strategy. This chapter will critically analyse the hybrid workplace strategy and define its properties, benefits, and limitations. The second research question will be answered, being:

*What is the hybrid workplace, and what are its benefits and challenges for the organisation?*

## 2.2 Workplace Alignment

The aim of corporate real estate management (CREM) is to improve organisational performance by aligning the real estate portfolio with the business strategy (Bon, 1992). However, increasingly, managers are looking for a way to integrate all company assets into this alignment method, especially human capital. Therefore, new theoretical models have been published, including the relationship between people and the physical environment. This management is called corporate real estate asset management (CREAM) and is defined as:

*Corporate real estate management integrates, directs, and supports the strategic alignment of all business processes and underlying business assets, including human capital, with the land, building and working environments of an organisation (Haynes et al., 2017).*

Haynes et al. (2017) capture this definition in the 10P CREAM model, seen in figure 2, which shows ten components, or organisational characteristics, that should be strategically aligned to reach optimum productivity and performance. In this model, an organisation's business *processes*, *purposes*, *positions* and *paradigms* should align with its underlying assets, *people* and *place* through sufficient *procurement*. If sustainability is considered, *planet* is supported. Finally, when strategically aligned, the P's above increase the strategic outputs *performance* and *productivity*.

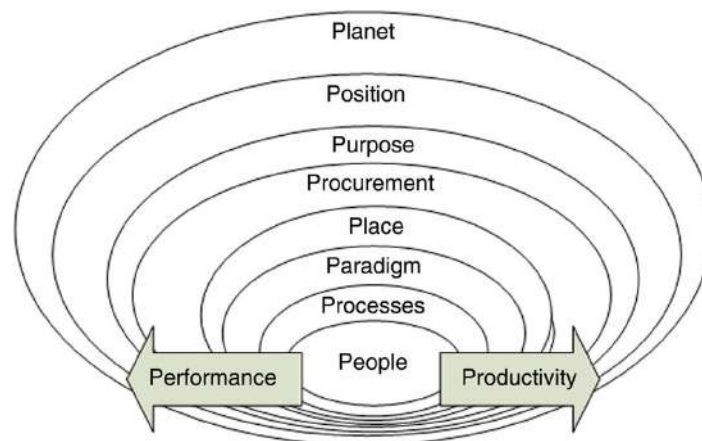

Figure 2: The 10P model (Haynes et al., 2017)

### 2.2.1 The ten P's

To better understand the ten organisational characteristics, each is elaborated on below. In the context of this research, each characteristic is viewed from the manager's perspective. The expected use of each organisational characteristic in a hybrid workplace is shortly discussed for each characteristic.

#### Position

This characteristic describes the position of an organisation in its market. In other words, it provides the context in which decisions regarding organisational strategy are made. For an organisation to make decisions and maintain health and future proof, it must understand the drivers, trends, and emerging technologies within the market. Next to this external position, this component also relates to the internal position. This regards the lifetime, or cycle, of the organisation.

To gain a complete understanding of one's organisation, a manager can undertake a PESTEL analysis, establishing the key drivers of the business's environment. Furthermore, a SWOT analysis is performed, analysing the internal assets of an organisation. Combining this external and internal knowledge can reveal the key opportunities and threats. Using this information in scenario planning, a manager can optimally adapt the CREAM strategy.

#### Position in the hybrid strategy

Anticipating, identifying, and reacting to the major trends within the business market is becoming a more complex task for corporate real estate managers. Due to, for example, globalisation, emerging technologies, sustainability expectations and increasing demand for flexibility, the office workspace is evolving into a more flexible style. In 2012, the following trends were identified by Harris (2012). A few were:

- The workplace is becoming a key enabler of a successful strategy
- Employees are connected physically and virtually
- Flexible spaces for teams, collaborations and creativity are becoming more important.
- The workplace is increasingly used to transfer organisational culture and values to the client.

Because of these trends, Haynes et al. (2017) believe that the office workplace will move away from the open-plan layouts to a more activity-based working strategy, which provides different neighbourhoods that each support a different type of work. This strategy is based on an organisation analysis, aligning the real estate more with the employee's needs. Therefore, it recognises employees' autonomy more and supports their activities better (Chapter 2.3.1). This complements research by Saurin et al. (2008), in which the future workplace is envisioned as a place that, among other requirements, must be:

- Highly technology enabled
- Provide the feeling of community to employees

Causing, for example:

- Employees move between physical and virtual spaces, the latter being the more important in reducing (travel) costs and delays.
- Geographical locations to become less important
- Communication technologies to become essential within the workspace

From these examples, it becomes clear that the hybrid workplace strategy was not only already widely researched from the start of the 21st century, but to many, it was also seen as the future of the office workplace. However, to successfully implement any type of office strategy, organisations must constantly analyse their position externally and internally to find the right alignment with their corporate strategy and the changed context of the market.

## Purpose

This component complements the positioning within the CREAM model. It refers to why and how an organisation responds to the business environment. These aspects are combined in the corporate strategy, defined by Johnson et al. (2008) as:

*Strategy is the direction and scope of an organisation over the long-term: which achieves advantage for the organisation through its configuration of resources within a challenging environment, meeting the needs of markets and fulfilling stakeholders' expectations.*

An organisation's corporate real estate must be aligned with its real estate strategy to increase its performance and competitive advantage (Singer et al., 2007). Because the linkage between the two is very important, real estate must be discussed and incorporated strategically. Multiple models are known that capture the different strategies, for example, the nine real estate strategies by Nourse and Roulac (1993). They provide a real estate strategy for nine different corporate strategy objectives, each impacting the office workplace. For example, suppose the strategic objective is focused on flexibility. In that case, the real estate strategy can accompany this by providing facilities and workspaces that can adapt to multiple uses, supporting the organisation's and employees' changing requirements.

Organisational culture also falls within the purpose of an organisation. According to Johnson et al. (2008), organisational culture can be captured in a web consisting of six elements: symbols, power structures, organisational culture, control systems, stories and rituals and routines. Managing real estate so buildings and spaces can manifest this culture can improve alignment within an organisation. Take furniture, for example. A type of casual furniture can complement the corporate culture when informal conversations and creative brainstorming are of adding value to a company.

Tools exist that corporate capture strategy. For instance, the table created by Nourse and Roulac (1993) and De Jonge (1996) identifies seven potential elements of added value and nine potential

driving forces for the organisation. Once filled in by company executives, the relationship between the forces and values can be interpreted as real estate strategy values, as seen in figure 3.

<i>Driving forces</i>	<i>Added values</i>						
	<i>Productivity</i>	<i>Costs</i>	<i>Risk</i>	<i>Value</i>	<i>Flexibility</i>	<i>Culture</i>	<i>PR &amp; Marketing</i>
<i>Products</i>	●	●	●	○	○	○	○
<i>Market</i>	○	○	●	○	●	○	●
<i>Technology</i>	●	○	●	○	●	●	○
<i>Production</i>	●	○	●	○	○	○	○
<i>Resources</i>	●	○	●	●	○	○	○
<i>Distribution</i>	○	○	●	○	○	○	●
<i>Sales</i>	○	●	●	○	○	○	●
<i>Growth</i>	○	○	●	○	○	○	●
<i>Profit</i>	○	●	●	●	○	○	○

Figure 3: Strategic link between driving forces and added values (Scheffer et al., 2006)

### Purpose of the hybrid strategy

Understanding the strategy and culture of an organisation is essential in times of organisation change (Haynes et al., 2017). Implementing a hybrid strategy is an example of this. There is no one-size-fits-all hybrid strategy (CBRE, 2021b); thus, the organisation must understand its culture, strategic values, and human assets. For the human asset, both the physical environment (comfortable furniture, type of desks, building appearance) and the behavioural environment (the way people interact and behave in the workplace) need to be analysed, the latter having the greatest impact on employees' perceived productivity.

### Paradigm

Paradigm views the previous chapter through a different lens. It looks deeper into the mission, values, micro-cultures and beliefs of an organisation and its employees: the organisational DNA (Haynes et al., 2017). Paradigm is the intellectual view of how things are and work, accepted by employees and the organisation (Kuhn, 1970). The paradigm can often be seen in the identity or brand of a company, which reflects and communicates its ethos. Real estate is part of this brand, as the internal and external appearance signals clients and employees. Therefore, integrating real estate with the paradigm of an organisation is essential for alignment.

Effective CREAM can support the management of change in an organisation. This so-called change management is defined as

*'the process of continually renewing an organisation's direction, structure, and capabilities to serve the ever-changing needs of external and internal customers' (Moran & Brightman, 2001).*

Paradigm is a difficult component to analyse, as it contains many factors which are often intangible, such as traits of an employee and unwritten rules. However, in 1980, the researcher

Hofstede created a model that could analyse workplace values from the perspective of national culture. In this, the organisational culture of countries can be compared based on six dimensions.

Furthermore, a manager can analyse the management system the organisation is demonstrating and define its mission, vision, personality, values, beliefs, and brand identity. Identifying mismatches or disconnections between these characteristics and corporate real estate is essential knowledge for alignment between an organisation's paradigm and its assets.

Historically, there has been a disconnect between an organisation's stated paradigm and the actual work culture in the office (Warzel & Petersen, 2021). It is easy for an organisation to use the words 'family-friendly,' 'transparent,' and 'inclusive' to describe their culture, but do they comply with these promises? Warzel and Petersen (2021) write that this is often not the case, as *...the stated and unstated goals of an organisation have rarely aligned with the health or stability of the employee.*

#### Paradigm in the hybrid strategy

Company culture takes decades to form and is seen as anchored and inflexible. The hybrid strategy cannot fix the issues Warzel and Petersen describe within this culture. However, the implementation does give an organisation a rare opportunity to tackle these problems and align the expectations and preferences of the organisation with those of the employees. When implementing a hybrid strategy, a deep understanding of 'the way things work' currently within an organisation is very important. The disconnects between employer and employee need to be identified, as well as workplace issues no one dares talk about. Clear expectations must be set at all levels of the organisation. The current workplace mindset and boundaries need to be broken, and the manager must take on a new role. For instance, how can they ensure employees will not endlessly overwork to prove their home working performance, like what happened during the pandemic.

#### Processes

The processes that take place in an organisation are no longer restricted to just the office environment. On the contrary, this paper argues that shifting to remote environments is inevitable for most organisations. However, the office workplace must still support some of the organisational processes. Realising appropriate real estate for the processes is essential for alignment.

Due to the challenges of globalisation and competition, it has become an increasingly complex task to support the processes within an organisation. These factors, combined with the development of information communication technology (ICT), have caused the need for workplaces to, for example, be flexible and to stimulate knowledge sharing. Also, the traditional office is no longer the best place to support processes. Due to ICT, work activities can happen in different places and ways.

Hardy et al. (2008) presented the distributed workplace model, illustrating its three components: working virtually, working out of the office, and working in the office, as seen in figure 4. The

balance of these three environments, and the space and connection between them, add up to the complete distributed workplace of an organisation. For every organisation, this balance is unique, as it is not only the nature of the activity that determines the distributed workplace but also organisational strategy, culture, and structure (Hardy et al., 2008). In the following figure, Hardy argues that contextual factors must be created that typify an organisation to design the work environment.

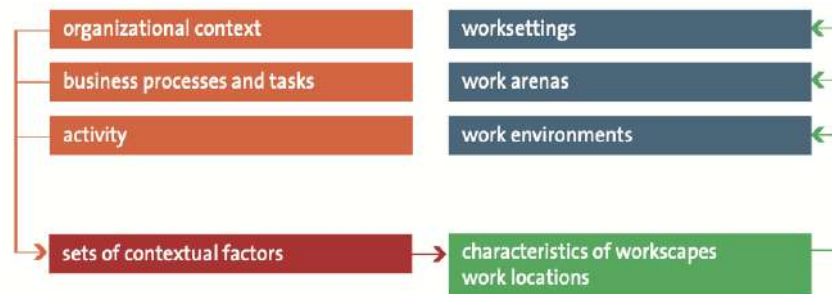

Figure 4: Aligning work environments with processes (Hardy et al., 2008)

A manager must thus first determine how the workplace is currently distributed. Different strategies should be implemented for each work environment to maximise the potential and minimise the disadvantages. For instance, protocols must be in place to support the introduction of flexible working, and research must be performed to determine if all processes are supported in activity-based workplaces (Haynes et al., 2017)

#### Processes in the hybrid strategy

As mentioned before, the distributed workplace supports all organisational processes. When an organisation with a more traditional office-focused work environment decides to implement a hybrid strategy, a new equilibrium between the three work environments will need to be found. The working in the office environment will reduce, whilst the environments working out of the office and working virtually increase, see figure 5. But by how much? And which processes do an organisation need to support in the office and which elsewhere?

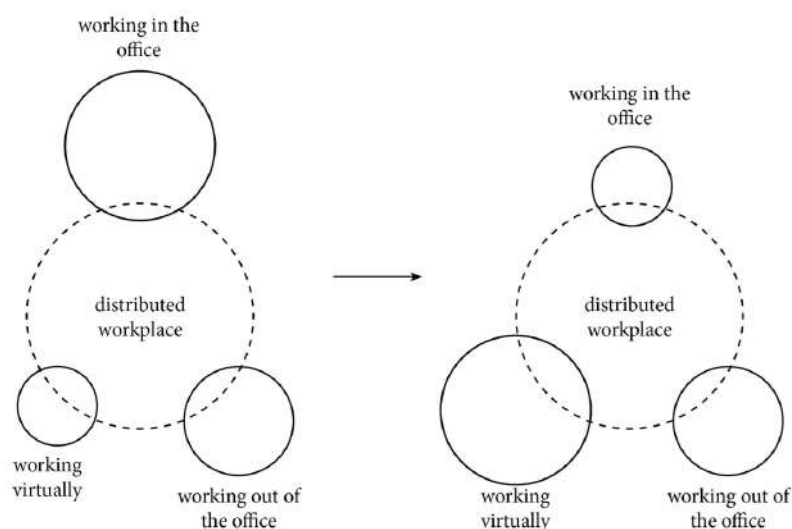

Figure 5: A changing equilibrium of the three work environments (Hardy et al., 2008)

## Procurement

Procurement is the process of acquiring real estate, whether bought or leased. During this procedure, real estate managers must ensure the acquired real estate is aligned with the processes, connects with the needs of the employees, and fits within an organisation's corporate strategy. And all this for the right price. Procurement is complex but essential due to the fast pace of the changing business environment. Increasingly, businesses are interested in more flexible and adaptable real estate procurement options. Since the 1990's leases have become shorter to meet these demands, eventually creating flexible (co-working) spaces that can be leased by the month, day and even hour; this way, organisations can react to the constant change in workspace demand (Haynes et al., 2017). After the lockdown of the Covid pandemic, many organisations realised this flexibility was a priority so that the real estate footprint could be reduced quickly.

The manager must thus determine why the organisation is procuring space and ensure that the business case is sufficient. Furthermore, the advantages and disadvantages of the available freehold and leasehold spaces must be evaluated. An extensive risk analysis must be performed before entering any kind of procurement.

### Procurement in the hybrid strategy

Procurement does not only regard an organisation's office. The hybrid strategy divides work processes between the home, office, and virtual environment (figure 5). The three environments are intertwined, and it is up to the real estate manager to balance them correctly. A manager can, for example, choose to provide their employees with the option to lease serviced offices, virtual offices, or co-working spaces. This is an office space with facilities, which can be anywhere.

## Place

Place, as a micro factor, is the corporate real estate component that first comes to mind when discussing the hybrid strategy. Place can suggest the virtual workplace, in and out of the office, and the layout and spatial design of the latter two. Also, place can be seen as a macro factor, such as the region, country or even continent in which the company is placed.

As mentioned before, a shift in the world of work is taking place, away from the traditional office and towards a more flexible, interactive and boundaryless environment. Corporate real estate managers must be aware of the changing demands of their employees and their clients their employees' and clients' changing demands. They must accompany these by organising sufficient accommodation and workspaces and aligning corporate strategy. Haynes et al. (2017) describe this strategic place planning process as:

*The identification and translation of the organisational and business need for accommodation space into cost-effective space solutions.*

Thus, it is essential to identify the organisational goals before making decisions regarding place or space. Only then place and space can be seen as an organisational recourse connected to the corporate strategy. An example is a model by Hardy et al. (2008), which can easily identify the in- and outputs of the matching process of corporate goals and corporate accommodation.



Figure 6: IPO diagram to identify corporate accommodation (Hardy et al., 2008)

### Place in the hybrid strategy

Haynes et al. (2017) explain each factor of the demand and supply side of the diagram by Hardy et al. (2008), seen in figure 6. This illustrates an organisation's strategic steps to align its place with its corporate goals. This section will do the same. However, it will analyse the diagram in an 'aligning to a hybrid strategy' situation.

### People

Employees interact with each other and the organisation's real estate. For everyone, this interaction is unique and is influenced by many factors, such as socio-demographic characteristics, personality, and culture. This makes it very complex to create a working environment that fits all needs and preferences. In that sense, plans such as the open-plan office, which carries the one-size-fits-all motto, have failed. A corporate real estate manager must better understand an organisation's workforce to find a fitting office solution, thus better aligning employees and real estate (Haynes, 2017).

### Generation

To start with, the workforce can be categorised by generation. This is still generalising, but it gives a helpful 'average' generation's expectation. A younger generation would, for instance, be more likely to welcome a hybrid strategy than an older one. These generations have a distinctive working style, preferences, and general view of work. Figure 7 shows the characteristics of each generation (Hammill, 2005).

WORKPLACE CHARACTERISTICS				
	Veterans (1922-1945)	Baby Boomers (1946-1964)	Generation X (1965-1980)	Generation Y (1981-2000)
Work Ethic and Values	Hard work Respect authority Sacrifice Duty before fun Adhere to rules	Workaholics Work efficiently Crusading causes Personal fulfillment Desire quality Question authority	Eliminate the task Self-reliance Want structure and direction Skeptical	What's next Multitasking Tenacity Entrepreneurial Tolerant Goal oriented
Work is ...	An obligation	An exciting adventure	A difficult challenge A contract	A means to an end Fulfillment
Leadership Style	Directive Command-and-control	Consensual Collegial	Everyone is the same Challenge others Ask why	*TBD
Interactive Style	Individual	Team player Loves to have meetings	Entrepreneur	Participative
Communications	Formal Memo	In person	Direct Immediate	E-mail Voice mail
Feedback and Rewards	No news is good news Satisfaction in a job well done	Don't appreciate it Money Title recognition	Sorry to interrupt, but how am I doing? Freedom is the best reward	Whenever I want it, at the push of a button Meaningful work
Messages That Motivate	Your experience is respected	You are valued You are needed	Do it your way Forget the rules	You will work with other bright, creative people
Work and Family Life	Ne'er the twain shall meet	No balance Work to live	Balance	Balance

Figure 7: Working style per generation (Hammill, 2005)

### Personality

Apart from expectations derived from one's generation, each employee has needs that arise from their personality. One way to link a personality to office space preferences was created by Oseland (2012). This OCEAN model shows the effects of the 'Big Five' personalities on interaction spaces, as shown in figure 8.

Less	Personality Type	More
Formal, familiar, traditional spaces	<i>Openness</i>	Face-to-face meetings, brainstorming, stimulating & new spaces
Informal and quick interactions	<i>Conscientiousness</i>	Planned, formal, well-organised, minuted meetings
Written communication, small groups, subdued spaces	<i>Extraversion</i>	Large group and face-to-face meetings, stimulating spaces
Unstructured face-to-face meetings where they can challenge	<i>Agreeableness</i>	Large meetings with structure to gain group consensus
Large, impromptu meetings, informal meeting spaces.	<i>Neuroticism (emotional stability)</i>	Well-planned meetings

Figure 8: Workplace aspects that support personality type (own illustration, based on Oseland, 2012)

### Gender

Differences also occur between female and male employees. Research (Stenerg et al., 1993; Kim et al., 2013) shows that female occupants of office space show lower satisfaction levels and more annoyance with the indoor climate than their male counterparts, mostly regarding the thermal environment, indoor air quality and the cleanliness of the workplace. More research shows the higher dissatisfaction of female workers in lower temperatures (Karjalainen, 2011).

## Culture

Cultural differences can have an impact on workplace alignment. In a study, Van Wijngaarden (2011) finds a lack of acknowledgement of the national culture among industrial professionals. The research concludes that a balanced understanding of the individual, group, organisational culture, and workplace strategy is needed for a successful workplace solution. National culture can be expressed in a workplace's interior design, for instance, in colour, materials, and art, increasing the feeling of belonging and pride (Van Wijngaarden, 2011). Therefore, cultural differences must be considered when establishing a real estate strategy.

Combined with data collected on their employees, this information can give corporate real estate managers estimates on how to create a real estate for their employees. Each subchapter mentioned above concludes that a one-size-fits-all will not achieve alignment within an organisation. Human capital cannot be seen as a single asset but as a collection of individuals, creating a unique workforce profile with unique preferences and needs. According to Haynes et al. (2017), generation Y employees expect a workplace supporting work, play, and rest. Also, a space to connect is preferred, in which creativity and informal encounters are stimulated stimulating creativity and informal encounters. Older office workers' needs are determined by their preferred work style.

### People in the hybrid strategy

When implementing a hybrid strategy, the workplace will change as the workforce knows it. This change influences the employees and thus the output of an organisation. Therefore, a corporate real estate manager must analyse the workforce's needs and preferences to envision the best solution. The hybrid strategy adds another factor to the people component, the home situation. Home situation refers to marital status, family situation, neighbourhood situation, amenities, spatial possibilities at home regarding an office etc. Because these factors can all affect the productivity and performance of an employee, finding a balanced hybrid solution can be very complex. An organisation must therefore stay flexible and constantly analyse the needs of its employees.

## Planet

Haynes et al. (2017) connect environmental sustainability to real estate with the concept of corporate social responsibility (CSR). This concept contains how an organisation reacts to its physical and social environment. Nowadays, organisations must comply with (inter)national standards to reduce global warming. An organisation can blindly follow these or choose to act and do more than the minimum, namely activities that fall within CSR. Also, organisations are becoming more sustainably aware, often integrating this into their vision, marketing, and product. These changes influence corporate real estate, for instance, workplace strategy and building materials (Haynes et al., 2017).

Brown (1998) defines a sustainable society as:

*A sustainable society satisfies its needs without diminishing the prospects of future generations.*

Is it up to the executives of an organisation to which extent to engage in these kinds of issues? CSR is to go beyond the legal minimum standards. Nowadays, this creates an image of a well-managed organisation.

Even though it often has been used as a facade for companies to appear to be CSR, it can also increase an organisation's productivity and performance when implemented properly. As the definition states, being sustainable is being futureproofed and resilient. Therefore, being sustainable is the most efficient and resilient way of managing an organisation.

As the occupier of an office, the corporate real estate manager must choose a sustainable building and sustainably design the workplace. Here, certifications are often used, such as BREEAM, LEED, CASBEE and Green Star Estidama, showing the level of sustainability of a building. Next to environmental sustainability, a manager must consider a sustainable work culture, including diversity, inclusiveness, and equity themes.

#### Planet in the hybrid strategy

Designing a workplace will have an impact on the sustainability performance of an office. The gap between a traditional and hybrid workplace strategy might be the biggest in this impact. Once an organisation chooses to reduce the number of daily occupants in the office, fewer employees will commute, and less space will be used, reducing its carbon footprint, for instance. However, an organisation must keep the increased footprint while working at home. The views of an organisation on CSR can impact the type of hybrid strategy. If the corporate strategy is to become as sustainable as possible without reducing performance, an organisation could choose a home-focused hybrid strategy, maximising their real estate footprint reduction.

#### Performance

To optimise and align business processes, the performance of an organisation must be measured, calculated, and benchmarked. When benchmarking, performance can be compared in different ways, internally and externally.

Performance is one of the two output components of the 10P model by Haynes et al. (2017). This component is split into two parts, efficiency and effectiveness. From an organisational point of view, the former is expressed in cost reduction or measured in cost/m<sup>2</sup>, for example. However, this number alone means nothing when not compared to the competition or another equivalent process. The latter, effectiveness, shows how much that process adds to the organisation's, for instance, profit/m<sup>2</sup>.

There are several different types of benchmarking in the real estate sector. External benchmarking is when an organisation compares itself to another (best-practice) organisation, such as strategic benchmarking, in which an organisation's long-term strategy is evaluated by comparing it to a best-practice organisation. There is also internal benchmarking, in which branches from the same organisation but in a different location are compared.

Gathering the data to benchmark can be a (time)costly process. Therefore, it is important for a manager that the goal of the benchmark is properly well thought out. The manager mostly chooses performance measurements from the following categories:

- Cost, for instance costs/workspace; real estate costs/m<sup>2</sup>
- Efficiency, for instance, space/employee; vacant space
- Utilisation, for instance, % of the office occupied per week; % of meeting rooms used
- Quality, for instance, employee satisfaction
- Environmental, for instance, building performance ratings.

#### Performance in the hybrid strategy

To benchmark before and after the transition to a hybrid strategy is essential to measure the impact of the change. Before choosing a hybrid strategy, an organisation should have considered a corporate strategy, real estate strategy, and goal. By benchmarking performance indicators that measure these goals, an organisation can calculate if the new hybrid workplace strategy has met its goals.

#### Productivity

Just like the output performance, productivity can be divided into two parts: productivity in the physical environment, the spatial design and indoor climate, and how employees interact and behave in the behavioural environment. If the components are aligned, a productive environment on an individual, team and organisational scale comes into being. Suppose this workplace can last and thus is future-proof or resilient. In that case, one can conclude that the work environment supports organisational goals, purpose, and culture, as well as employees' unique needs and preferences and the processes between them: the ten P's are aligned.

#### Physical productivity

Although much research has been performed connecting productivity to the physical design of an office, such as the layout, no one-size-fits-all solution has been found—however, a vast amount of research points toward a strong connection between the work environment and productivity. For instance, Gensler (2005) researched this connection and found that productivity could increase by 19% if employees worked in a better environment. The same research also concludes that 79% of employees find the quality of their work environment essential for their work satisfaction. Other research points out that 18 billion pounds could be saved in the UK if office space was used more efficiently (Bootle and Kaylan, 2002).

#### Behavioural productivity

The other, less tangible side of productivity is the behaviour of the occupants of a workplace. Addressing this type of productivity is complex, as each employee sees social behaviour and interaction differently. The way the physical office can influence this social aspect will be addressed in this subchapter.

### Personalisation

For over three decades, research has addressed employees' behaviour regarding personal space in the office. Becker and Steele (1995) propose a non-territorial workplace with no dedicated desks. Wells (2000) claims the opposite is needed, as productivity and wellbeing are higher when employees can personalise their workspace.

### Concentration vs collaboration

Another issue in the workplace where tensions are created is the balance between concentration and collaborative space. Brenner and Cornell (1994) researched this topic by analysing employees' trade-offs when choosing a common, collaborative or private space. They concluded that, over time, the employees increasingly chose the common space over the private space as team feeling increased. Ultimately, Becker and Steele (1995) conclude that an organisation must analyse the specific processes that happen in a workplace to be able to align the physical design with an organisation's strategic goals. This way, if it is an objective to change company culture, the workplace design can be used as an instrument for this change.

### Interaction vs distraction

According to a study by Olson (2002), being able to perform distraction-free individual work was rated as the highest workplace quality that affects the performance of employees. However, spontaneous interactions scored second. These two opposites are needed in a productive workplace, but the type of workplace strategy can favour one of these qualities. Open-plan offices often have little spaces without distraction, for example. Mawson (2002) would advise against such a workplace layout, as he claims productivity increases the longer an employee can focus on a task without distraction. The longer an employee concentrates, the deeper their flow state is. From this assumption, Mawson (2002) concludes that the office must be a distraction-free space. However, Haynes (2005) finds this conclusion limited, as it does not consider personality types and other processes, such as collaborative work.

Office managers must therefore find an office design that supports high levels of interaction but simultaneously decreases the level of distraction. Haynes (2005) proposes it is time for a paradigm shift towards an occupier-focussed spatial design of the workplace.

### Productivity in the hybrid strategy

The essence of a hybrid strategy is the implementation of remote work, which will greatly impact the physical and behavioural environment and, thus on, productivity. Changing a part of the current system will disturb the balance. Therefore, when managers transition to a hybrid workplace strategy, the design of the new workplace can become a complex issue. To reduce risks, an occupier-focussed approach is needed (Haynes et al., 2007), analysing employees' productivity and linking these to design components. This can help when finding a new balance in the workplace.

### 2.2.2 Discussion

The 10P CREAM model attempts to align real estate asset management components with organisational strategy, views, and goals. It becomes clear that corporate real estate management is not only about considering all components but also finding the relation and the correct balance between them. One organisation can have a completely different vision, goal, or culture than the next, resulting in a very different implementation of the components. It is up to management to integrate these components, which are unique for every organisation, in its real estate. This is an extremely complex challenge, especially when an organisation plans to switch from a workplace strategy.

## 2.3 The Hybrid Workplace

The hybrid workplace is a strategy in which the physical office and any kind of remote work are combined. (Cook et al., 2020). To glue these two environments together, an ICT network is in place to support virtual connectivity (Hardy et al., 2008). Because the structure of ICT networks differs from the physical workplace, this study limits itself to the physical components within the office and remote work environments. However, it does acknowledge that a reliable ICT network and virtual space are needed to support the connectivity of the hybrid work environment (Bosua et al., 2012) as a requirement when implementing a hybrid strategy.

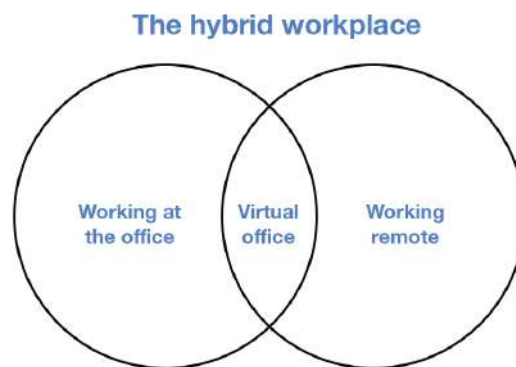

Figure 9: The hybrid office (own illustration based on Cook et al., 2020)

Before the corona crisis hit in 2019, the average Dutch employee worked at home for 3,8 hours a week. These employees have the preference to increase this to 9 hours a week in post-Covid times. Here we see the new equilibrium already being formed, as organisations predict to implement 8 hours of working from home every week on average. Even so, this large increase in remote work will massively impact workplace design and the processes within a short period (Centraal Planbureau, 2021).

### 2.3.1 Remote work benefits

When implemented properly, the employee enjoys a better work-life balance, works more autonomously and commutes less. The employer can reduce their real estate footprint and many other costs whilst maintaining equal productivity. And, not to forget, homeworking's external benefits on society and the environment. Even if organisations choose to let their employees work from home only one day in the week, €1,6 billion could be saved in The Netherlands alone due to, among other things, reductions in traffic, traffic accidents and sick leave (PWC, 2020a) Homeworking during the Dutch lockdown period also resulted in the CO<sub>2</sub> produced by traffic to reduce by 20% as well as an increase in air quality (Ministerie van Infrastructuur en Waterstaat, 2021).

For the past two decades, the effects of remote work have increasingly been studied. The research concludes the benefits to employees to be:

- Increased level of employee performance (Conradie & De Klerk, 2019; Lee, 2018; Rudolph & Baltes, 2017)
- Increased level of concentration and fewer distractions (Conradie & De Klerk, 2019; Lee, 2018; Rudolph & Baltes, 2017; Gajendran & Harrison, 2007; Kazekami, 2020; McNaughton et al., 2014)
- Improvement of health and well-being (Mache et al., 2020; Rudolph & Baltes, 2017)
- Increased level of engagement (Anitha, 2014; Conradie & De Klerk, 2019; Rudolph & Baltes, 2017; Ten Brummelhuis et al., 2012)
- Higher level of job satisfaction and commitment (De Klerk et al., 2021; Gajendran & Harrison, 2007; Kazekami, 2020)
- Higher productivity due to time saved by not commuting (McNaughton et al., 2014)

Also, remote work proves to be beneficial to the organisation in the form of:

- Increased financial returns (Khodakarami & Dirani, 2020)
- Organisational effectiveness (Khodakarami & Dirani, 2020)
- Reduced amount of employee absenteeism (Schaufeli, 2013)

### 2.3.2 Remote work challenges

Past research also shows challenges that come with this flexible strategy. The following issues arise when remote work is performed extensively:

- Decreased levels of employee collaboration (Boell et al., 2013)
- Increased levels of social isolation resulting in less significant social connections (McNaughton et al., 2014; Vander Elst et al., 2017)
- Increased work-family conflicts (Eddleston & Mulki, 2017)
- Increase of uncompensated work (Warzel & Petersen, 2021)

Grant, the author of the quote in the introduction, discusses one of the dangers of using a hybrid workplace: *the proximity bias*. Managers reward employees they see in person. Therefore, employees will do the same when a manager chooses to work on, for example, Wednesday and Friday. However, minorities, such as those with caretaking responsibilities, disabled people and people that must commute longer, are less likely to come to work these days. This could cause a diversity crisis, increasing the gap between the privileged and the minority (Grant, 2022). BBC's Worklife writer, Bryan Lufkin, adds to this by emphasising the dangers of a male-dominated office in a hybrid concept. On average, women take on a disproportionate share of the unpaid household and childcare responsibilities. Therefore, they would choose to work from home more, increasing the proximity bias. Warzel and Petersen (2021) agree and warn about the post-pandemic hybrid scenario in which the workplace favours the same people as before.

They continue to argue that during home working in the pandemic, many employees worked extra hours to compensate for time lost to childcare responsibilities. Others felt pressured to work extended hours out of fear of losing their job. The home working environment can quickly become toxic, with little personal connection, anxiety, and unpaid labour (Warzel & Petersen, 2021).

### 2.3.3 Remote work requirements

Like any other workplace strategy, the hybrid workplace is complex. When implementing the hybrid strategy, an organisation must be open to redesigning the corporate culture.

- The organisational culture must be supportive (Perlow & Kelly, 2014). This means employees must be cared for by their organisation with, for example, sufficient home office facilities and supportive supervisors (Wood et al., 2020).
- The organisational structure must be built on trust. This creates tension and an unhealthy work environment (Perlow & Kelly, 2014).
- The organisation must constantly try to understand employee needs and develop these within the organisational culture, to maintain and improve the employee experience (Plaskoff, 2017).
- An increase in production, up to 19% (Bloom et al., 2015), can only be established in situations where 1) a reliable ICT network was implemented (Bosua et al., 2012), 2) organisational structure was based on trust between manager and employee (Bosua et al., 2012; Nakrošienė et al., 2019) and 3) a well-furnished home workplace was in place (Nakrošienė et al., 2019).
- Face-to-face communication remains essential in a hybrid strategy (Coenen en Kok, 2014). Too little can result in negative productivity (Kazekami, 2020). Pataki-Bittó and Kapusy (2021) and Tagliaro en Migliore (2021) suggest keeping office functions that support socialising, collaboration and brainstorming. This complements the conclusions by Kraut et al. (2002), which envisions the future office workplace as a creativity booster and knowledge producer.
- Implicit knowledge is difficult to share via telecommunication and needs a physical place to be successfully transferred (Lee et al., 2007).

### 2.3.3 Discussion

Using remote work in a workplace strategy has clear benefits, according to many studies, such as higher concentration, job satisfaction and productivity. However, remote work also comes with multiple challenges and requirements, such as a higher risk of work-family conflicts and reduced collaboration. Both sides are important to consider when implementing a hybrid strategy.

According to this literature, employee and organisational productivity and performance can drop if one or more requirements are unmet. If they are met, implementing remote work in the workplace strategy can bring various benefits. A manager must analyse their organisation extensively to determine if an organisation has the recourses to implement a hybrid strategy. If so, the manager must then analyse if the needs and preferences of the organisation and the employee are met in this strategy.

## 3. Methodology

This research is split into four parts to understand the use of organisational characteristics in the transition to a hybrid workplace (see chapter Readers Guide). Each part contributes to answering the main question. This chapter will elaborate on these parts, which method is used and how the objective is achieved.

### 3.1 Type of study

This research aims to understand how organisational characteristics are used to transition to a hybrid workplace. This research will first make broad observations of already implemented hybrid workplaces. With this information, a generalisation can be made to support managers planning to make this transition in the future.

In other words, this research will collect data to understand how organisational characteristics are used in the transition to a hybrid workplace. This way of research, reasoning from specific observations towards broad generalisations, indicates *inductive research*. Inductive research uses this method to describe social characteristics and the nature and network of social regularities (Blaikie & Priest, 2019). Because this research deals with *how* a societal phenomenon works, a qualitative approach is appropriate. Qualitative data is often collected as words and then simplified and analysed in other words, not numbers (Blaikie & Priest, 2019; Eisenhart, 1989).

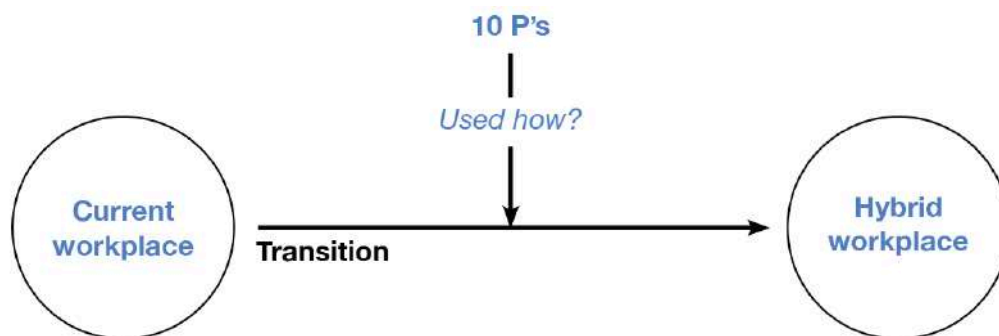

Figure 10: Research framework (own illustration)

## 3.2 Part 1: Background

Part one introduces the research context and the problem within this environment. It uses an explorative literature study to collect this information. Online newspaper articles, scientific publications and corporate management theory books are data sources. Bryman (2005) calls this kind of explorative literature study a narrative review of collecting and examining the literature of what already is known. This narrative review introduced the research problem. After this, sub-questions have been created that scope the rest of the research.

This part also integrates various explorative interviews to understand the context better. These interviews were conducted as unstructured interviews with participants active in the field of corporate real estate. Participants were selected pragmatically, consisting of available professionals willing to converse. This information was used to frame the research problem, gain a better insight into the topical challenges, and reduce researchers' bias.

## 3.3 Part 2: Theories & Models

In part two, the literature study is continued. However, a different style of study is used, namely a systematic literature study. The previously performed explorative literature study is a foundation of the systematic literature study. According to Bryman (2005), the objective of this study is to research the topic more extensively and in-depth "to minimise bias through exhaustive literature searches of published and unpublished studies". Academic research, as well as reports, books, interviews, podcasts, websites, and surveys, are used as data sources.

The first two sub-questions are answered with the collected data from part 2, namely:

Sub question 1: *What are the organisational characteristics, and how are they used in workplace management?*

Sub question 2: *What is the hybrid workplace, and what are its benefits and challenges for the organisation?*

### 3.4 Part 3: Findings

The last two parts introduce a complex societal challenge and an unsolved problem that comes with it: how organisational characteristics are used in the transition to a hybrid workplace. Data on organisational characteristics used in already implemented hybrid workplaces will be collected to solve this problem. These findings are presented and compared in part three. This data will be used to answer the following sub-questions.

Sub question 3: *With which characteristics can an organisation be described?*

Sub question 4: *How are these characteristics used in the current workplace design?*

Sub question 5: *Based on which organisational characteristics are decisions made in the transition to a hybrid workplace? And how are these reflected in the design solutions?*

The completed transitions of hybrid workplaces will be analysed to collect the information. The focus of these analyses is to understand how organisational characteristics are used. *Case studies* will be used as the method of this research. According to Yin (2003), case studies are suitable if the boundaries between a complex phenomenon and its context are unclear. In the context of this research, how organisational characteristics are used is a complex phenomenon, and the transition to a hybrid workplace is its context.

Furthermore, this data collection technique is suitable for single-person research with limited time and budget. At the same time, it allows the researcher to study an aspect of a problem with some depth (Blaxter et al., 2002; Bell, 2005). All of which apply to this research.

#### 3.4.1 Case study criteria

Corporate real estate management (Haynes et al., 2017) highlights the use of organisational characteristics to create a tailored workplace. The case study will therefore investigate a transition project of an organisation which has implemented a hybrid workplace. A single-case study of this transition is possible. However, it is liable to the risk that the case is not representative. A two-case study could produce outcomes that are not empirical, also known as replication (Bryman, 2005; Yin, 2003). Therefore, it is suggested to research more than two cases.

To gain access to (information on) these kinds of cases, a graduation research position at a real estate firm was sought that could provide the research with previous hybrid workplace projects. After exploratory interviews with several firms, an agreement with Dev\_ real estate was realised due to the following reasons:

Dev\_ real estate has experience in:

- Project management, including hybrid office concept
- Workplace consulting, including hybrid strategies
- Real estate development, including hybrid offices

Also, Dev\_ real estate can provide:

- Direct contact with stakeholders involved in hybrid transition projects

- Internal reports and primary information on hybrid transition projects
- Experienced guidance of graduation projects

Selection criteria are set to select cases that produce the desired information on organisational characteristics. Firstly, the sector in which case organisations are active is demarcated to make representative conclusions. According to Centraal Planbureau (2021), the financial- and services and public sector in The Netherlands expects to work from home for 41 per cent and 35 per cent respectively of all working hours in the post-Covid era. These are the biggest expected changes in the country. Therefore, the cases must be active in these sectors, as the results have the highest chance of making an impact. Additionally, the workplaces that undergo the transition must be located in The Netherlands. Otherwise, large differences in national culture can impact how representative the case is.

Secondly, as this research aims to understand the use of organisational characteristics in the transition to a hybrid workplace, the cases ought to have made a transition from a workplace mainly supporting in-office activities to a workplace supporting both in-office and home working, i.e., the transition to a hybrid workplace. A way to measure this is by comparing the flex factor of the workplace pre-transition and post-transition. The flex factor is the ratio of workspaces available in-office and the number of full-time employees. This indicates the degree of the hybrid strategy. For instance, a flex-factor of 0,6 in an organisation of 1,000 full-time employees indicates a capacity of 600 workspaces in the office. Thus, the cases should have transitioned from a high flex-factor (less hybrid) to a low flex-factor (more hybrid). Figure 11 lists all the selection criteria.

Criteria	Clarification
An organisation in the trades and services or public sector	To make generalisations within sectors in which it will have the largest impact
The organisation is situated in The Netherlands	Minimalizes differences caused by national culture.
The organisation underwent a workplace transition from a high flex-factor to a low flex-factor	Indicated a transition to a hybrid workplace from a less hybrid workplace

Figure 11: Selection criteria used during theoretical sampling (own illustration)

### 3.4.2 Case study selection

The number of previous projects at Dev\_ real estate was large. To run all projects by these criteria would be a timely process. Therefore, explorative interviews are conducted with fifteen real estate experts working for the graduation organisation. In these interviews, the professionals were asked if they had previously worked on any workplace projects which included any kind of hybrid strategy. These interviews are unstructured but point out the purpose and aims of this research. From these interviews, nine cases were selected that could meet the case study criteria.

After applying these criteria to the nine potential cases, three cases are selected to perform a case study. These cases are shortly elaborated on below:

### Case 1: The Droogbak, Clifford Chance, Amsterdam

Since 2000, the Droogbak has been the workplace of the Dutch branch of the international law firm Clifford Chance. Four years before their 20-year lease agreement ended, the organisation started to think about the future of the workplace. With an architect, a workplace consultant and a project manager, management decided to renovate the Droogbak. This renovation would, among other interventions, bring the flex-factor down from 1 to 0,84.

### Case 2: HUB50, Nederlandse Politie, Utrecht

HUB50 is a building acquired by the Dutch Police in 2019. The building would accommodate the organization-wide integration and densification of real estate. Eventually, the plan was made to move an IT department into the building, which was now divided into three outdated offices elsewhere. A new, hybrid work concept was introduced during the process, setting the flex-factor at 0,49.

### Case 3: Utrecht Central Office, VodafoneZiggo, Utrecht

Utrecht Central Office is the headquarters of the Dutch telecom organisation VodafoneZiggo. The workplace opened in 2018. During the pandemic lockdowns between 2020 and 2022, the organisation decided to introduce a new, hybrid work concept, as the Utrecht Central Office was often overcrowded. The new work concept brought the flex-factor down to 0,6.

#### 3.4.3 Data Collection & Reduction

A major benefit of case studies is the opportunity to use multiple data sources. Not only does this technique address a broader range of issues, but it also increases the accuracy of the findings (Yin, 2003). In each of the three cases, three data sources are used to collect data on organisational characteristics in the transition. This so-called triangulation of data is portrayed in figure 11. Each source is approached with a different data collection, reduction, and coding technique. These techniques are elaborated on below.

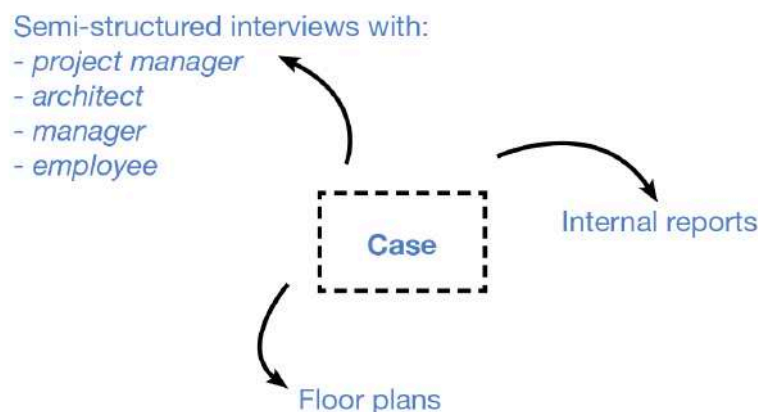

Figure 12: The three data sources per case (own illustration based on Yin, 2003)

### 1. Interviews

Interviews are conducted with stakeholders that play an essential role in the transition toward the hybrid workplace. Because many perspectives exist in a transition, stakeholder groups are created. By interviewing at least one person from each of the four stakeholder groups, this research aims to collect accurate data. The stakeholder groups are:

1. The architect
2. The project manager
3. The employee
4. The employer, decision-maker, or real estate manager.

Together with the project manager, who was active during the specific case, potential interviewees are contacted via email by the researcher. These were chosen based on availability and level of influence in the transition. This invitation is sent, including two documents, one containing additional information and another containing the informed consent agreement. These documents can be found in Appendix A and B.

The data collection aims to collect data that can, after being analysed, answer the sub-questions. Therefore, the interviews are guided by three interview questions, each relating to one of the sub-questions. However, probing the participants for additional details or perspectives can be resourceful and crucial to understanding which and *how* organisational characteristics are used in the transition. Therefore, the interviews are semi-structured.

This interview is audio-recorded to transcribe the answers afterwards. After data reduction, the data will be fully anonymous, and the recording will be deleted. More information on the ethical use of data can be found in chapter 3.6.

The interview is first transcribed to be reduced and coded using several steps. Firstly, the answers are transcription is summarised into shorter quotes which contain the main message. These quotes are coded with a characteristic code, referring to one of the ten P's explained in chapter 2.3, a phase code, referring to separate phases in the transition and a connection code, referring to a connection, for instance, between a key driver and a supporting design solution, a challenge and its solution or an employee and their daily processes. These codes are listed in figure 13. As all interviews are conducted in Dutch, English keywords that summarise the Dutch quotes are added to refer to the quote in the English analysis.

Each interview is then visualised into an *individual transition timeline*, showing which characteristic is used in which phase and how it connects to the next. These timelines are compared, and a *case transition timeline* is created by finding similarities in all timelines within a case. This is presented in the within-case analysis.

Code group		
Phase code	Component code	Connection code
1.1 Understanding corporate strategy	2.1 Processes	3.1 Indirect or low influence/impact
1.2 Understanding real estate performance	2.2 Purposes	3.2 Direct or high influence/impact
1.3 Creating a real estate strategy	2.3 Positions	
1.4 Implementing the strategy	2.4 Paradigms	
1.5 Other	2.5 People	
	2.6 Place	
	2.7 Procurement	
	2.8 Planet	
	2.9 Performance	
	2.10 Productivity	
	2.11 Other	

Figure 13: List of codes used during the reduction of interview data

## 2. Internal reports

The researcher collects the internal reports from the cloud storage of the graduation organisation. With permission from the employees of the graduation organisation, the files regarding the transition of the relevant hybrid workplace are viewed. Unfortunately, the internal documents for case 2 are all classified and cannot be accessed for this research.

The documents are reduced and visualised to be analysed comparatively. The outputs are:

- An organisation charts
- A brief history of the organisation
- The mission and values of the organisation
- A timeline of the transition
- Key drivers before and during the transition

## 3. Floor plans

Floor plans are collected from the cloud storage of the graduation organisation. Data is collected from the plans of the currently implemented workplace and the future hybrid workplace plans. The floor plans must show all spaces in the building, including the (office) furniture.

For analysis, the floor plan is reduced by coding each space in the building with a workspace code, referring to the intended spatial use. These codes are based on research by the Centre for People and Building (Hofkamp et al., 2013). Then, the surface of that floor is calculated using AutoCAD, a program used for technical drawings. In Excel, the same table for each case calculates the ratio of types of spaces. These calculations are visualised to simplify the data for analysis and the sensitivity of the information.

The outputs of this reduced data are the following.

- The total square metres of the office
- The ratio of work, collaborative, and facility spaces
- The number of workspaces
- The number of FTE
- The flex-factor

The data collection plan, seen in figure 14, shows which sources provide data for which sub-question. When more sources are used, the more accurate the data becomes.

Sub question	Source	Case 1	Case 2	Case 3
1	Interviews	•	•	•
	Internal reports	•		•
	Floor plans	•		
2	Interviews	•	•	•
	Internal reports	•		•
	Floor plans	•	•	
3	Interviews	•	•	•
	Internal reports	•		•
	Floor plans	•	•	•

Figure 14: Data collection plan

### 3.4.4 Within-case analysis

The findings are presented in the case report. Each report consists of a case introduction, the findings of three sub-questions, and a discussion.

The introduction describes the case and provides general knowledge. The findings and the three sub-questions consist of the collected and reduced data—figure 14 shows which source is used for which sub-question. The case report discussion elaborates on data collected, for instance, the differences and similarities of the perspectives of the interviewees and the phases in the transition. Furthermore, the discussion visualised organisational characteristics in the transition using the coded interview data to create a timeline. The timeline shows only the characteristics and phases that the interviewees commonly perceive.



Figure 15: From sub-questions to case report (own illustration)

## 3.5 Part 4: Synthesis

The knowledge is compared and discussed in the final part of this research. It consists of cross-case analysis, literature discussion, and conclusion.

### 3.5.1 Cross-case analysis

The separate case reports are specific observations. These observations are used to create broad generalisations to complete the inductive research. First, the reports are cross analysed by finding similarities and differences for each sub-question. A final, common answer to the sub-questions is given.

### 3.5.2 Discussion with literature

The within-case and cross-case analyses have provided sufficient information on how organisational characteristics are used in implemented transitions to hybrid workplaces. This chapter combined this knowledge with the literature study to discuss each organisational characteristic. Here, the ten organisational characteristics are first defined as they are according to Haynes et al. (2017). Then a summary is provided of the tasks the authors recommend the real estate manager to execute. This is compared against the tasks performed by the managers in practice. This way, the 10P model can be critically discussed as a method for post-pandemic hybrid workplace transitions.

### 3.5.3 Conclusion

The conclusions of the different organisational characteristics are combined to provide a general understanding of how organisational characteristics are used in the transition to a hybrid workplace in the trades and services sector and public sector in The Netherlands. Key takeaways will be given based on the differences and similarities between the use of organisational characteristics defined in the literature and the practical use in the field. This chapter will answer the main research question, being:

*How are organisational characteristics used in the transition to a hybrid workplace?*

### 3.6 Ethical considerations

In any research, it is crucial to consider research ethics. Research ethics is a code of norms, values, and institutional arrangements researchers use during research, such as transparency, respect, and objectiveness. All of which are considered in this research. Different ethics must be considered when performing empirical research involving people, such as discrimination and confidentiality (Resnik, 2020). It is the responsibility to map out the risks that could harm participants of social research and integrate mitigation in their research plan. This research takes multiple precautions to reduce found risks.

During case studies, sensitive data may be collected regarding the security of buildings, internal disputes, managerial choices, or organisational performance. This data can be collected from all three sources: interviews, internal reports, and floor plans. Therefore, the following precautions are made before data collection to mitigate the risks of this data being misused, leaked, or misinterpreted.

- Before all interviews, the participant is explained that all data will be used anonymously. All personal information that is recorded will not be transcribed. The only information is the type of role of the participant within the organisation.
- The participant is also informed that the thesis will be published publicly on the database of the TU Delft. Therefore, the participant is given a chance to read the to-be-published thesis in its final form to check for information that ought not to be released.
- The participant is asked for permission for the interview to be audio recorded. This accordance is given verbally or, if desired, an informed consent document is signed. This form is added as appendix A. The recording is used to transcribe the interview. The recording is saved on the password-coded local storage of the researchers' mobile phone, mitigating a data leak. As explained in 3.4.3, this data is reduced into quotes, keywords, and a single organisational characteristic, minimising the risk of using sensitive information. Then the recording is deleted.

### 3.7 Summary

In the following table, an overview is provided of the research parts.

Type of research: Inductive	
Approach: Qualitative	
Part 1: Background	
Method	Explorative literature research and exploratory interviews
Objective	Introduce the topic area and research problem
Sub questions	-
Part 2: Theories & Models	
Method	Systematic literature research
Objective	Study research environment and gather background information
Sub questions	Sub question 1: What are the organisational characteristics and how are they used in workplace management? Sub question 2: What is the hybrid workplace and what are its benefits and challenges for the organisation?
Part 3: Findings	
Method	Case study research
Objective	Collect, code, reduce and analyse data
Sub questions	Sub question 3: With which characteristics can an organisation be described? Sub question 4: How are these characteristics used in the current workplace design? Sub question 5: Based on which organisational characteristics are decisions made in the transition to a hybrid workplace? And how are these reflected in the design solutions?
Part 4: Synthesis	
Method	Theory building
Objective	Draw conclusions and create generalisation
Main question	How are organisational characteristics used in the transition to a hybrid workplace?

Figure 16: Overview of methodology, objective, and question per research part (own illustration)

---

## Part 3: Findings

## 4. Case Studies

This chapter elaborates on the findings of the case studies per case. These findings result from reduced data from internal reports, interviews, and floor plans. The findings will be presented as an answer to the sub-questions 4, 5 and 6.

## 4.1 Case A: Clifford Chance | Droogbak

### 4.1.1 Introduction

Case A consists of the renovation of the building the *Droogbak* from a cellular workplace to a hybrid workplace. The users of this office are the employees of the Dutch branch of Clifford Chance, an international law firm. Over the course of three months, five interviews were held with stakeholders of this renovation. These stakeholders will be referred to as interviewees A through E, as seen below. Other sources used are presentations in the transition regarding planning and important decisions, expert workplace studies, Clifford Chance's website, and floor plans of the previous, current, and future workplace. Furthermore, both a manager and the project manager gave a guided tour.

Interviewee A: The project manager

Interviewee B: The facilities manager

Interviewee C: The general manager

Interviewee D: The architect

Interviewee E: An employee



Figure 17: The Droogbak, located next to the central station in Amsterdam (Clifford Chance Amsterdam, 2021a)

#### 4.1.2 With which characteristics can the organisation be described?

Clifford Chance is a state-of-the-art law firm founded by a merger in 1987 (Clifford Chance, 2022). It ranks as one of the world's top ten law firms measured by the number of lawyers, namely around 3300, and amount of revenue, which stands at around \$1.8 billion in 2020. Clifford Chance is a fully integrated, global partnership with 7255 employees worldwide, working in 34 cities and 23 countries.

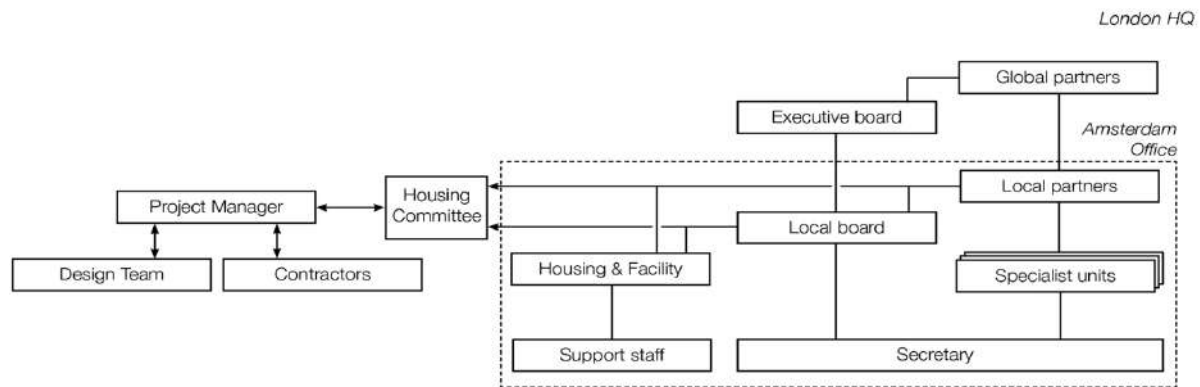

Figure 18: Organisation chart of organisation and stakeholder connections during the transition of the Droogbak (own illustration based on Interviewee A)

Their quality lies in providing the highest quality of (local) in-depth advice and legal expertise brought to the client (corporates from all the commercial and industrial sectors, the financial investor community, governments, regulators, trade bodies and not-for-profit organisations) using a team-based and approachable working style (Clifford Chance, 2022; Interviewee A; Interviewee C). They present their vision as the global law firm of choice for the world's leading businesses today and tomorrow. In short, the firm aims to produce the best advice for the best client provided by the best lawyers (Interviewee A). The key to being the best is Clifford Chance's ability for employees to work together between specialities within the firm and between countries (Interviewee C).

It tries to provide a high-quality experience for clients and employees in an informal, progressive, and open manner (interviewee D, Interviewee E).

The organisation has a partner structure (see figure 18) in which the 20 local partners are active lawyers and owners of the office. Each partner has a team of specialists, junior lawyers, and a secretary (Interviewee A).

#### 4.1.3 How are these characteristics used in the current workplace design?

The origins of Clifford Chance's office in The Netherlands lie Amsterdam-Zuid, the financial centre of The Netherlands. In 1972, Clifford (pre-merger) opened its first office on the Apollolaan. Thirteen years after the merger, in 2000, the firm relocated to a building named the Droogbak in the centre of Amsterdam (Interviewee B). In 2000, the organisation agreed on a 20-year agreement with owner Allianz to lease the Droogbak, a large, prestigious four-storey administrative office of the first Dutch railway company. It gained a monumental status in 2001. The building currently houses 273 employees (Interviewee B).

In the case of Clifford & Chance, three-floor plans are compared. Firstly, its previous office, located at Apollolaan 171 Amsterdam. The second and third third-floor plans are both located at Droogbak 1 Amsterdam. These floor plans are of before and after the renovation. Figure 19 shows the main findings of the data collection.

On the Apollolaan, the organisation rented an already furnished office. The office had a cellular layout, a popular Dutch office design. Clifford Chance prioritises employee retention and high-quality training of young talent (interviewee B). The cellular office supported this work well, as senior lawyers received their own office, and a junior lawyer would join them to be close to the action (Interviewee B; Interviewee C). Most times, the senior lawyer would also have a secretary in their office. This supported the fast-paced work and reflected the hierarchical structure of the firm, as assignments and commands could be passed down to the junior lawyer and secretary in the blink of an eye.

Due to company expansion, more space was needed. Therefore, the organisation moved to the Droogbak. This move, however, was unusual for a firm in this sector, as the organisation moved away from the city's financial area to the city centre. This decision was made so Clifford Chance could distinguish itself even more from the competition (Interviewee A; Interviewee C).

The organisation continued to distinguish itself by implementing an informal work culture, such as its informal dress code (Interviewee A). This would reflect their unique youthfulness and a horizontal organisation. The location and informal dress code would also help the organisation appear more attractive, supporting the law in talent and client attraction (Interviewee D).

The spatial layout in the Droogbak was similar to that of Apollolaan: a clear, repetitive cellular office in which partners received their room. They would share this space with a junior for a direct learning experience and sometimes with a secretary for efficiency (Interviewee B).

Big changes are perceived when comparing the old and new Droogbak floor plans. Firstly, parts of the first and second floor are to be sublet, causing the reduction in total office surface. The average individual workspace increased, caused by the open plan concept on the third floor and the merging of rooms on the first and second floors. An increase in the ratio of collaborative and meeting space is measured. However, when measuring these spaces separately, their size is reduced by 36 per cent. This is caused by the addition of 20 relatively small brainstorming rooms.

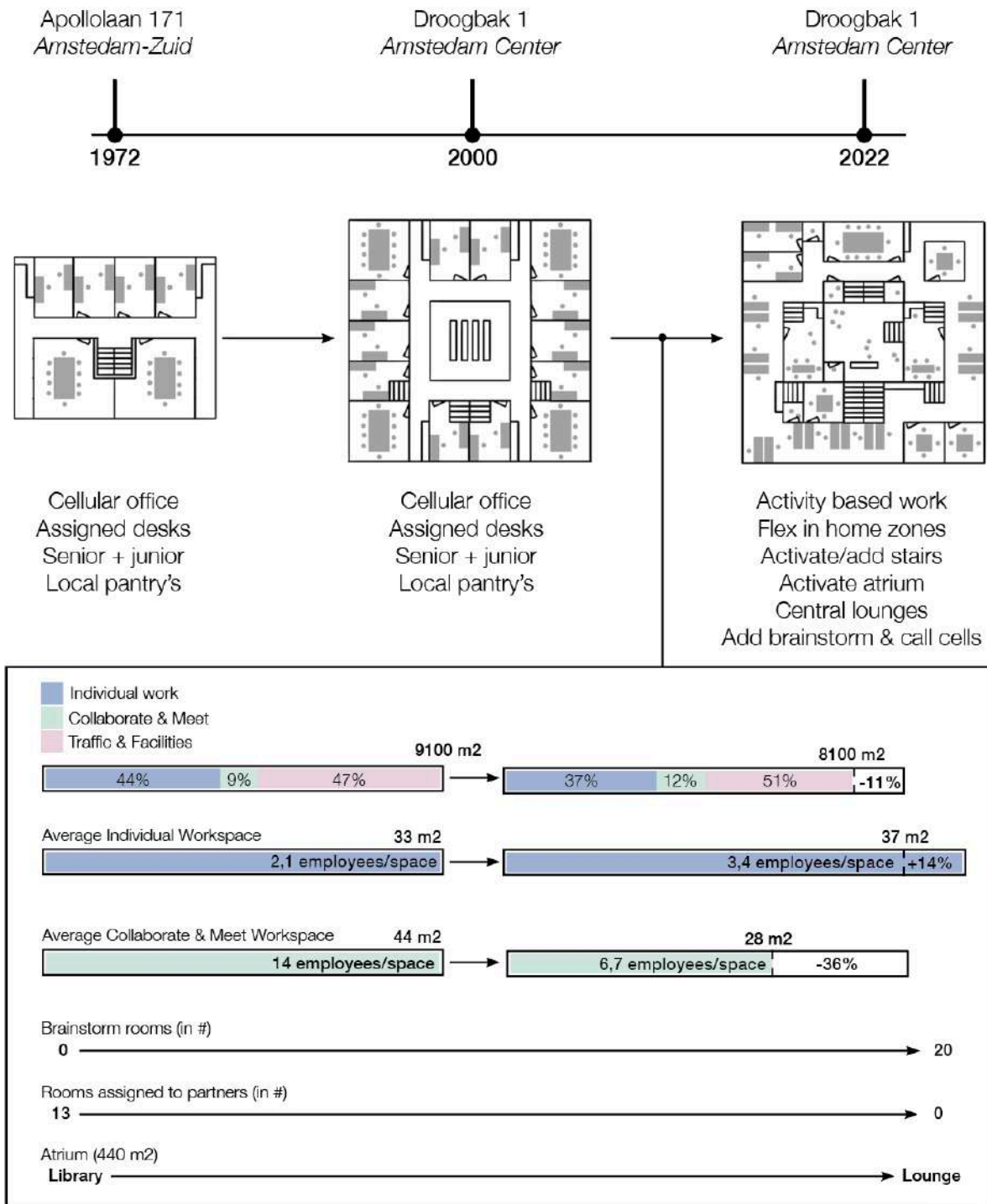

Figure 19: Schematic layout and floor plan analysis of the Droogbak (own illustration based on internal reports and Verbeek, 2020)

An attractive appearance for potential talent, client attraction, and employee retention are key drivers supporting the firm's position in the market (Interviewee A, Interviewee D). Over the years, Clifford Chance has found a way to distinguish itself: an externally aesthetically pleasing office in a unique and central location in the capital (Interviewee B). However, as flexibility, globalisation and employee awareness are becoming more important, this workplace does not perform sufficiently. Not only does the outdated fit-out not align with the appearance goals of the firm,

but its office layout and work culture do not align with its informal, progressive, and cross-functional collaborative values (Interviewee B; Interviewee D). For instance, the assigned rooms for partners no longer fit how the organisation wants to present itself (Interviewee B; Interviewee E). Instead, open, transparent, and flexible work floors are to be created that provide different spaces tailored to one's activities. Clifford Chance is thus changing the workplace, organisational work culture, and *paradigm*.

The future office reflects this shift with its hybrid work concept, activity-based work floors, unassigned desks, new and activated staircases, improved routing, connectivity hubs, a welcoming, open atrium, seen in figure 19, dynamic colours, transparent work floors, state-of-the-art technology, and custom design furniture (Interviewee D).

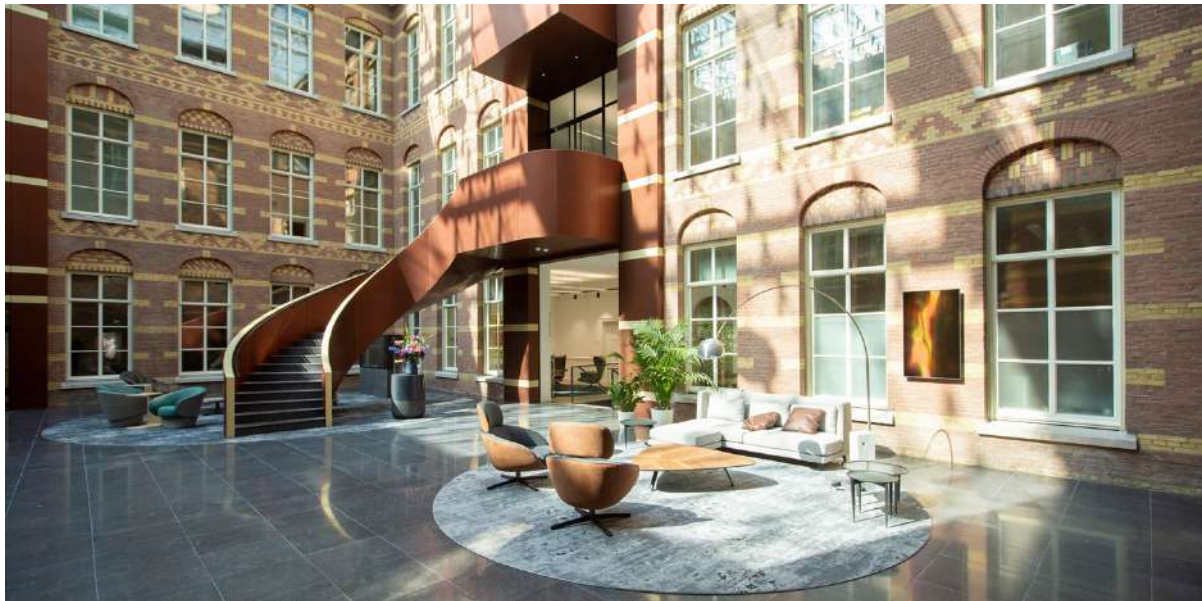

Figure 20: The multi-functional atrium of Clifford Chance's workplace (Clifford Chance Amsterdam, 2021b)

The hybrid strategy's flexibility fits the employees' daily activities pre-Covid, as many lawyers were travelling and enjoying a high-quality IT network. Therefore, many employees were used to remote working culture. However, the flexibility of activity-based working is a drastic change, as partner lawyers now, in theory, must let go of their assigned space (Interviewee D). This space now becomes a space for the whole team or, if located on the third floor, for anyone.

This intervention points out the paradigm shift the firm is undergoing. Managers and employees point out the unjustified formal and traditional external appearance of the office's building (Interviewee B; Interviewee C; Interviewee E). On the one hand, the building should show its dynamic, young, and informal feeling and support more cross-functional collaboration (Interviewee C).

4.1.4 Based on which organisational characteristics are decisions made in the transition to a hybrid workplace? And how are these reflected in the design solutions?

In 2016, four years before the end of their lease agreement, Clifford Chance began internally to think about their future in this workplace (Interviewee A; Interviewee B). As seen in figure 15, external advisors were hired to support the process. A housing committee consisting of partners, facility management and operational managers was formed. This team would serve as a think tank and communicator between contractors, specialists, and the group of partners (Interviewee A; Interviewee B; Interviewee C). As the partners are the owners of this office of the organisation, they can make the final call. Translating their (personal) needs and preferences and convincing them of their future workplace plans was important, and it was a challenging task (Interviewee A; Interviewee C).

Clifford Chance and the advisors Cushman & Wakefield and Dev\_ real estate chose a bottom-up, location-independent study of employees and their work-related activities (Interviewee A). This study used leadership interviews, workplace surveys and focused groups on analysing employees' daily processes and needs. Internal reports conclude five key pillars for their future real estate:

- Innovative technology
- Enabling Workstyles
- Attraction and Retention
- Five-star client experience
- Unique Identity

The possibility of hybrid working was never a goal (Interviewee C). However, working for a state-of-the-art international law firm, the workforce was used to a light version of hybrid work, as lawyers would fly to clients and use technology to support this flexible working style (Interviewee B). When the study of their employees pointed out that a form of hybrid work could fit with the activities of Clifford Chance, the housing committee researched the acceptance of this idea to the partner group. It was decided that a form of hybrid work was preferable. However, no agreement on the level of hybridity was made. First, a location scenario was to be performed (Interviewee A; Interviewee D).

For this research, new experts were hired, this time the architect firm Fokkema. Together with Dev\_ real estate, a stay-or-go analysis began. Multiple scenarios were created, including staying in the Droogbak with a light renovation, staying in the Droogbak with a big renovation or moving to a different location. The employee research-backed these scenarios, cost estimates, references, and artist impressions (Interviewee A; Interviewee D).

Due to a combination of (at the time) a tight office market and the benefits and uniqueness of the Droogbak location, the partners decided in December 2017 to stay in the Droogbak (Interviewee B). However, a complete renovation would need to occur as the current workplace underperformed when benchmarked against the employee research findings.

Based on the five pillars, the Droogbak renovation must realise more openness, collaboration and connection between teams and spaces and a more attractive appearance internally

(Interviewee C). This would accommodate the employees' wishes, create an attractive work environment for (potential) employees and align the workplace with the organisational paradigm. This was achieved with a flexible activity-based working concept throughout the building, accommodated with a flex factor of 0,84.

Because of the hindrance due to the building being monumental, the renovation could hardly change anything structurally (Interviewee D). When the third floor appeared less monumental, the team took the opportunity and reimagined the floor completely. This third floor would be a showcase of their modern, flexible work environment: open spaces with no assigned desks, separate meeting, brainstorming, and call cell room separated by glass walls for visibility and connection, and new coffee corners to stimulate cross-collaboration and informal meetings and attractive living room-like areas to relax in (Interviewee D).

The two floors below, the first and second, would be visibly less flexible. However, rooms were merged where possible to create fewer boxed-in work areas. Brainstorm rooms were added at the end of corridors to support multiple activities throughout the day. New, large (95m<sup>2</sup> per floor) two-storey pantry lounges were created on both the north and south side of the building to increase cross-collaboration and informal meetings. The new staircases within these lounges would also stimulate movement through the building. The work concept on these floors would not be fully activity-based but, as the architect called it, flexing in home zones. Here, a partner 'receives' an area of the floor with, on average, 0,84 desks per employee in which their team can work.

The ground floor saw a large change. The stuffy, old library in the atrium was to become the heart of the office had succeeded (interviewee A; Interviewee B; Interviewee C; Interviewee D; Interviewee E). A coffee bar, call cells, work desks, relaxation spots and a spiral staircase create an attractive and popular space. Not only did this 440m<sup>2</sup> area become a lively centre for employees to grab a coffee, rest or even conduct formal meetings, but it also invited clients into the building (Interviewee B). This openness to clients seems unique in law firms, as their routes and movements are often restricted and controlled (Interviewee C; Interviewee D). This would accommodate their mission of providing a high-quality client experience.

Another large impact on daily activities is the new restaurant on the basement level and coffee bar in the atrium. What were lesser used attributes before, these two areas are now used by almost everyone, increasing movements through the building immensely (Interviewee A, Interviewee C; Interviewee E).

This transition is visualised in a timeline in the figure below.

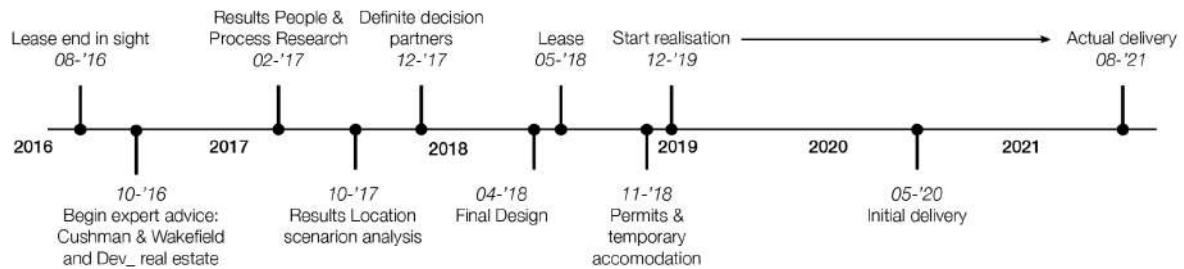

Figure 21: Timeline renovation Droogbak (own illustration based on internal reports)

#### 4.1.5 Discussion

According to all stakeholders, the transition of the Droogbak is incentivised by the characteristic procurement, namely the end of the lease agreement. At the same time, the stakeholders are aware of the underperforming workplace. This combination forms the first phase of the transition.

The organisation sets up a housing committee to determine what a well-performing workplace would be and then accommodate this transition. This committee consults workplace experts and performs *people* and *process* research on its employees' needs, preferences, and activities. Moreover, Clifford Chance's *position* in the market is to be at the top and provide the best product and service. These characteristics form the second phase of the transition.

In the next phase, the organisation's views on its market position are translated into more concrete requirements for the future workplace: an attractive appearance and location and a shift towards a modern, flexible work concept. This further supports its distinguishing state-of-the-art *position*. In collaboration with the architect, the employee research needs and preferences are translated into workplace design solutions that improve *productivity*, such as a new, high-quality fit-out, more support for collaboration and meetings, more routing, and more connectivity throughout the building.

Several locations and *places* are analysed to see how they meet these requirements. Finally, the Droogbak is decided on, and the design solutions are adjusted to this layout and its monumental limitations.

The final phase takes place after completion and will continue for years. This phase consists of the change management of the *paradigm* shift the organisation is undergoing. The organisation will use the hybrid workplace to move away from the traditional, hierarchical, and closed work culture of law firms and move towards an open, flexible, modern, and collaborative style. Most stakeholders agree that this change will be challenging due to the rooted workplace traditions of the organisation.

The phases and use of organisational characteristics are simplified and visualised in figure 22.

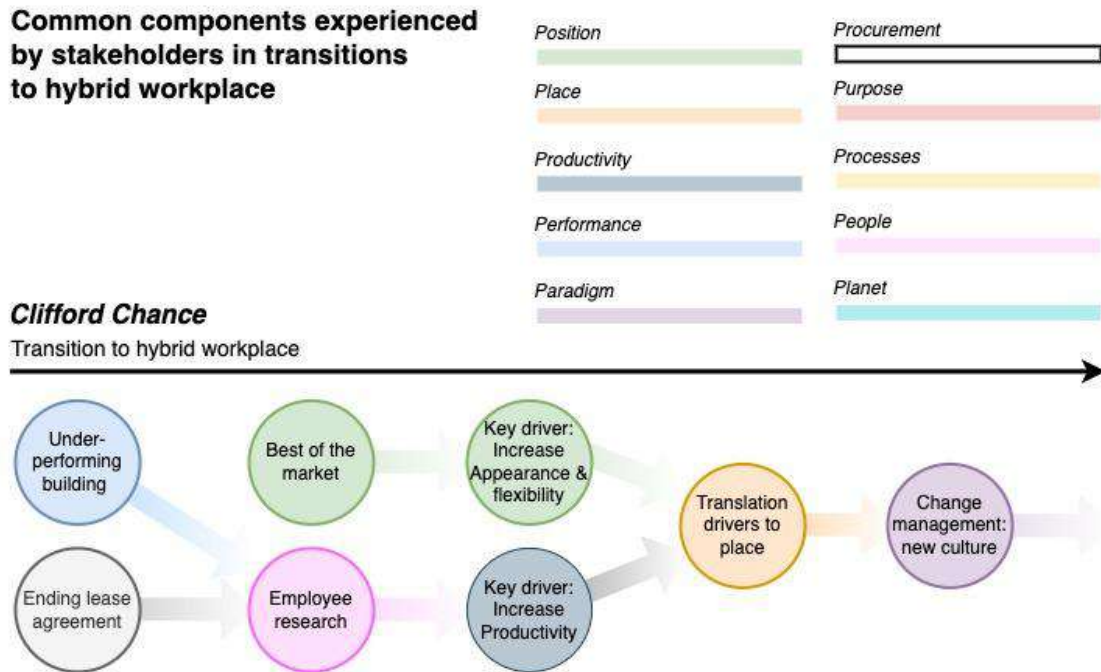

Figure 22: The visualisation of phases and use of organisational characteristics in the renovation of the Droogbak (own illustration based on Haynes et al., 2017)

## 4.2 Case B: Nederlandse Politie | HUB50

### 4.2.1 Introduction

Case B consists of the move to and renovation of the building *HUB50*, seen in figure 23. The building will house the so-called IV-groups, an application management department within the Dutch Police. The building will also provide space for visitors and other police employees. Over a period of four months, four stakeholders are interviewed. Even though many documents are classified, simplified floor plans and public records have been used as data sources. Furthermore, a guided tour was given by the project manager.

Interviewee F: Project Manager

Interviewee G: Manager

Interviewee H: Architect

Interviewee I: Employee



Figure 23: The HUB50, located centrally in The Netherlands (Nederlandse Politie, 2021d)

#### 4.2.2 With which characteristics can the organisation be described?

The Nederlandse Politie is the national police service in The Netherlands. Guilds initiated locally organised public protection in The Netherlands from 1581. In 1810 Napoleon introduced a national organised unit. Since then, the police have been re-organised multiple times. The last being in 2013, when the 25 separately managed Dutch regions were merged into an organisation led by a single leader, the *korpschef* (Nederlandse Politie, 2021b). This merger added more complexity to the already complex organisation (Interviewee F; Interviewee G; Interviewee H). The police employed over 62 thousand employees in 2020, making it the country's largest employer. (Nederlandse Politie, 2021a).

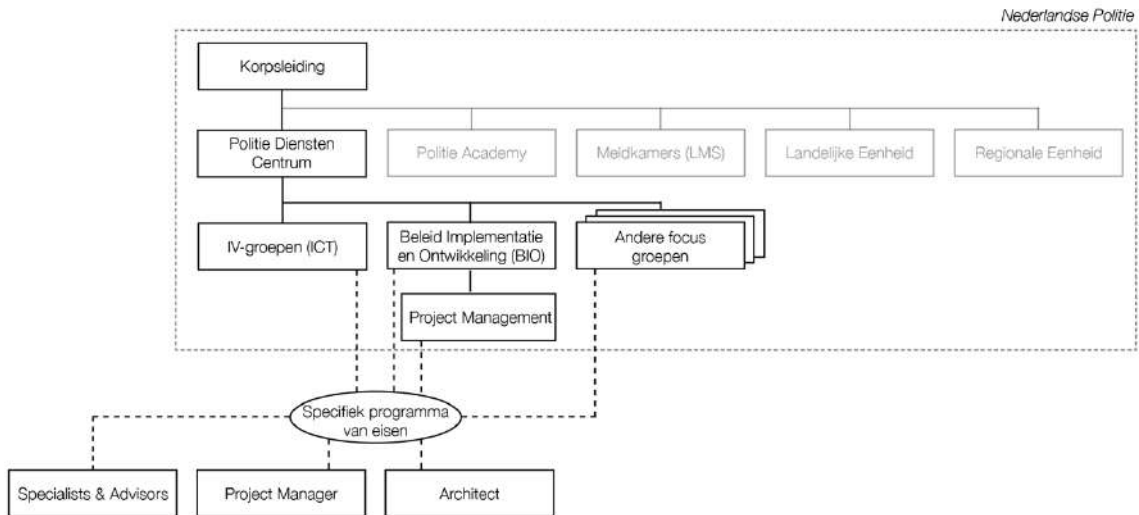

Figure 24: Organisation chart of organisation and stakeholder connections during the transition of HUB50 (own illustration based on Interviewee D & Nederlandse Politie, 2021b)

The goal of the Dutch police is to make The Netherlands safer (Nederlandse Politie, 2021c). Their mission is to constantly remain "vigilant and subservient" to the values of the rule of law (interviewee H; Nederlandse Politie, 2021b). Throughout the different roles within the police, many different activities are performed. This, together with being a National-led organisation that must be locally involved with the people, makes management extremely complex (Interviewee G). On top of this internal complexity, the police must stay updated with the fast-paced societal, technological, and criminal activities (Nederlandse Politie, 2021b).

Furthermore, as the police is a governmental organisation, costs are paid with tax money, making cost-cutting a priority (interviewee G). Another consequence of this form of organisation is the organisation's slow, political, and hierarchical decision-making (Interviewee I). This also means the police adhere to the sustainability goals of the Dutch government, which is to be CO2 neutral in 2050 (Nederlandse Politie, 2020).

Therefore, the Dutch police have started organisation-wide interventions to integrate facilities and activities more, increase cross-functional collaboration and flexibility through activity-based working, innovation and cut costs (Interviewee G).

The segment of the organisation in question in this research is the so-called IIV groups. The goal of these employees is to monitor, manage, and develop the mobile applications used by operational police staff (interviewee I). Mostly, this group works on project-based agile scrum teams (interviewee H; Interviewee I).

#### 4.2.3 How are these characteristics used in the current workplace design?

The Dutch police have a real estate portfolio of 1599 buildings, of which 269 are office buildings (Nederlandse Politie, 2021a). Many buildings underperform and need renovation (interviewee B, interviewee C). The police are increasing their real estate portfolio's efficiency and effectiveness countrywide (Nederlandse Politie, 2020). Pre-Covid, the police introduced the working concept of *Integral Working* to support this change. This concept allows any employee to use any building, spreading out occupancy, introducing activity-based work, and integrating previously detached teams into one building. These changes allow for a reduction in real estate, accompanying cost control and sustainability goals. This footprint reduction frees up financial resources to improve the quality of the real estate.

Three of the police office buildings previously housed the IV groups. These separate offices are spread out across the country (Interviewee I). The office varies in two layouts. Either a floor has an open work floor or a cellular layout. The rooms on the cellular floors fit four up to 20 employees. The agile scrum teams assign the open work floors and larger cellular rooms to support many people during a sprint session (Interviewee I). Per floor, a few call cells have been added to support calls and meetings. The rest of the building has a standard cafeteria, localised coffee corners and basic furniture (Interviewee G).

Also, here the integral working concept was implemented. However, the underperforming building did not sufficiently support this concept. Firstly, the internet connection was poor throughout the building. Secondly, the agile scrum rooms were too small for the growing teams. Also, insufficient office equipment was provided. Due to these reasons, the workforce mainly often worked at home (Interviewee I).

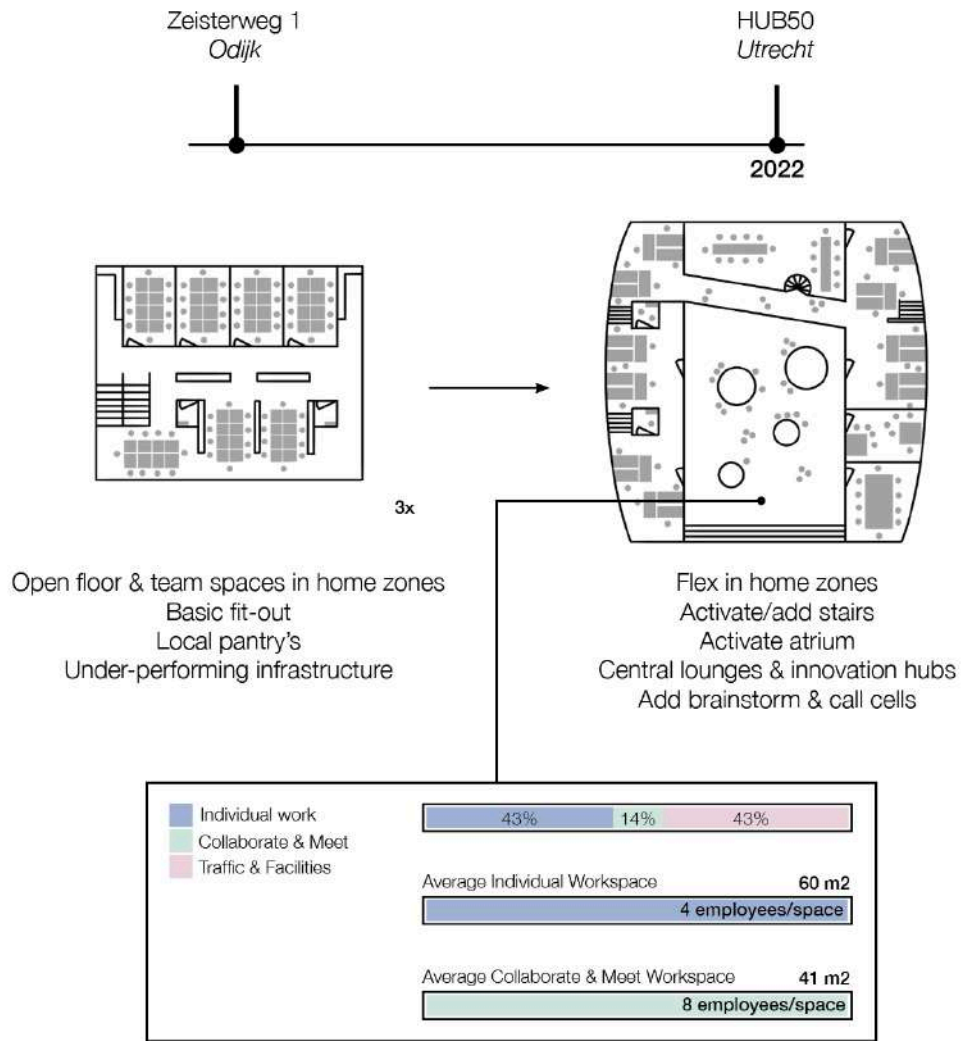

Figure 25: Schematic layout and floor plan analysis of HUB50 (own illustration based on floor plan analysis)

4.2.4 Based on which organisational characteristics are decisions made in the transition to a hybrid workplace? And how are these reflected in the design solutions?

To accompany the reduction of real estate and increase the integration of teams, a new building was acquired by the Dutch Police to house all three IV groups together: the HUB50 (Interviewee G). This building is located centrally in the country in the city of Utrecht (Interviewee F).

Before final decisions on renovating the building, the police performed employee research. This way, they could accompany the needs and preferences of the IV groups as well as possible. Using surveys, meetings, monitoring, and scrum boards, the future users could have a say in their future workplace. The police also created ambassador roles, which would facilitate employee questions. Some issues regarding the future workplace are still unclear. (Interviewee I). During this period, which was simultaneously the lockdown period, the research results pointed toward a different type of work concept. The employees had the preference to work more from home than the integral working concept indicated would happen (Interviewee F, Interviewee G). Therefore, a new concept was developed: *Different Working*. This concept was more flexible than the last one. Its main change was hybrid working, as now scrum teams were expected to work in the office an average of two days a week (Interviewee F).

Now the HUB50 could be renovated with this concept in mind. Due to a higher home working rate, a large building area was freed up. This would be used to meet the innovation and flexibility goals of the organisation. The building would be an office for the IV groups and a showcase for the whole organisation, inviting employees of other offices, clients or even the public. It is therefore fitted with congress rooms, high-end forensic research rooms and workshop and collaboration spaces (interviewee F).

These spatial arrangements were considered before hiring an architect (interviewee H). The ground floor would become a multifunctional atrium, where employees could meet each other or clients, eat and drink, rest, brainstorm, or work. The rooms surrounding the atrium are large meeting rooms that users and visiting employees can reserve. The four floors above are less public to visitors and mainly consist of open work floors for the IV-group teams. These floors would be flexible in the sense of flexing in home zones. Every team receives the same area to work in for the two days of in-office work. Within this space, there are no assigned desks (Interviewee F; Interviewee I).

The architect was hired later in the process. At that time, there was little room for adjustments in the plans. However, the architect found a few ways to implement changes they thought fit. Namely, as integration and collaboration are key drivers in real estate for the police, a centrally located spiral staircase was added (Interviewee F; Interviewee H). Also, as many of the activities in the IV groups can be seen as monotonous, the architect added '*innovation squares*' on the bridges between the office spaces. These squares each have a theme, such as well-being or creativity, and are meant to inspire employees (Interviewee H). Another design solution was adding more windows on the office walls facing the atrium. This reflects the horizontal management structure of the organisation (Interviewee H). Also, different colours and furniture were used on each floor, reflecting the complexity and dynamic nature of the organisation. This

way, anyone who walks through the door can find a spot where they feel at home (Interviewee H).

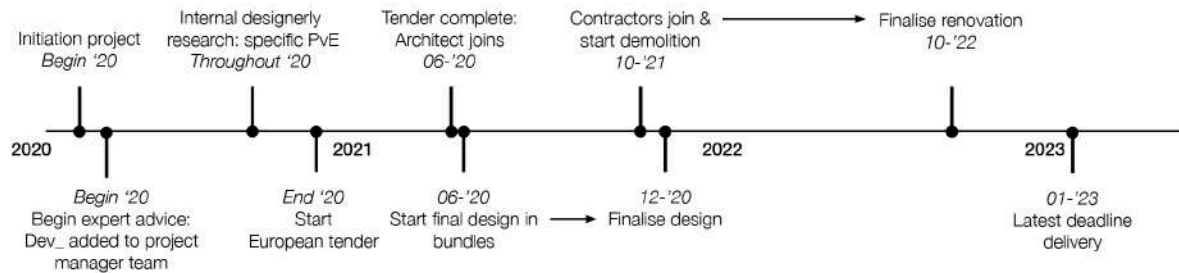

Figure 26: Timeline move to and renovation of HUB50

#### 4.2.5 Discussion

Since its reorganisation in 2013, the Dutch Police have struggled with complexity, *underperforming* workplaces, and cost-cutting.

An organisation-wide plan to densify, integrate and upgrade real estate was created to tackle this challenge. This *procurement* plan was the reason for acquiring and moving to the building HUB50. Simultaneously, the Police researched who the new users would be and, when they decided, what the needs and preferences would be of this group. This was done in collaboration with workplace experts.

The research results indicated that a hybrid workplace with a high flex-factor and support for agile team activities would accommodate the users' processes. This created room in the building to reflect the *position* of the Dutch Police in its market, namely showcase its innovation, technology, and activities.

Next, these key drivers are translated to design solutions, started with a 'spot plan' and later worked out by the architect. The new *place* would reflect the new norm for real estate within the Police by showcasing a flexible, integrated, densified, multifunctional, transparent, and diverse workplace.

The final phase is accommodating this new workplace and work culture norm within the Police. This is done by creating ambassador roles that can answer the question of employees and try-out workplaces. These ambassadors, however, cannot answer all questions, and the try-out locations are not made easily accessible. It is unknown how the users will react to the *paradigm* shift assisted by their future hybrid workplace.

The phases and use of organisational characteristics are simplified and visualised in figure 27.

**Common components experienced by stakeholders in transitions to hybrid workplace**

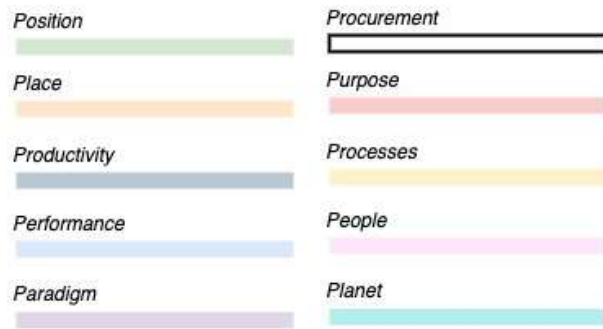

**Dutch Police**

Transition to hybrid workplace

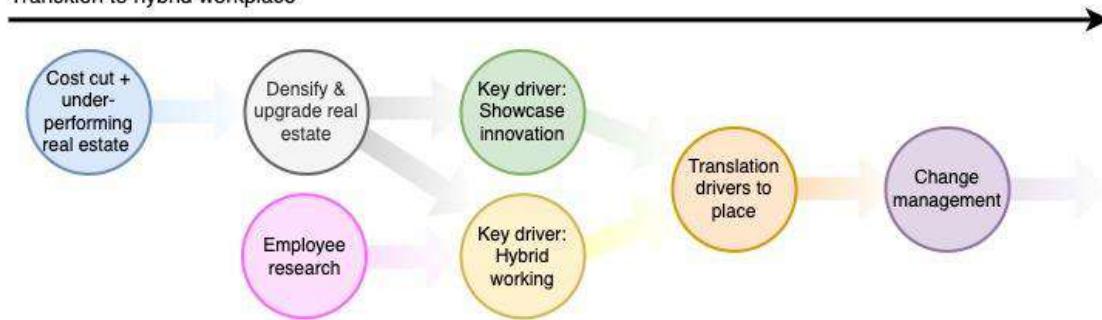

Figure 27: The visualisation of phases and use of organisational characteristics in the renovation of HUB50 (own illustration based on Haynes et al., 2017)

## 4.3 Case C: VodafoneZiggo | Utrecht Central Office

### 4.3.1 Introduction

The third case concerns the renovation of Utrecht Central Office, the headquarters of VodafoneZiggo in Utrecht. The current workplace does not support the activities of employees and the occupancy rates and will transition to a hybrid workplace. Over three months, four interviews have taken place with stakeholders in this transition. Despite some sources being unavailable for security reasons, public records and presentations regarding decisions and design during the transition were used to gather information.

Interviewee J: Project manager

Interviewee K: Facilities manager

Interviewee L: Work concept architect

Interviewee M: Employee representative



Figure 28: VodafoneZiggo's Central Office opposite Utrecht Central Station (VodafoneZiggo, 2017b)

### 4.3.2 With which characteristics can the organisation be described?

VodafoneZiggo is a Dutch company that provides fixed, mobile, and integrated communication and entertainment services to consumers and businesses. VodafoneZiggo is a joint venture between Liberty Global, the largest international TV and broadband internet company, and Vodafone Group, one of the world's largest telecommunications companies (VodafoneZiggo, 2017a). The company is a result of a 2017 joint venture between Vodafone and Liberty Global.

By 2020, the organisation provides over 3.8 million households with a telecom service and holds over 5.1 million regular mobile subscription customers. The firm counts over 8 thousand employees (VodafoneZiggo, 2020).

Regarding real estate, VodafoneZiggo owns nine offices, of which Utrecht is the headquarters, and over 125 shops in The Netherlands (Interviewee K).

VodafoneZiggo's mission is to have fun and progress with every connection (interviewee B). It does this by efficiently using its technology and people, for instance, constantly collecting data on occupancy and employee office use (Interviewee J). The firm is young, dynamic, and innovative and likes to use this to attract young talent (interviewee K). Its structure seems somewhat hierarchical, as the more people you know, the faster something gets done (Interviewee J; Interviewee K).

The interviewee's views on key drivers of real estate change in the organisation contradict each other, as cost control is mentioned as the key driver but also as "definitely not the key driver". However, all participants agree on another key driver: the organisation is constantly searching for how to best support (the activities of) the employee.

Lastly, the overall work culture has been changing since the merger in 2017. The organisation has been acting increasingly as a corporation instead of an IT firm (interviewee L). With this comes the use of more often agile scrum teams. These teams are flexible and come together now and then to divide, discuss, and iterate work. This means an office either has a low occupancy when scrum teams are not together or high when they decide to meet (interviewee L).

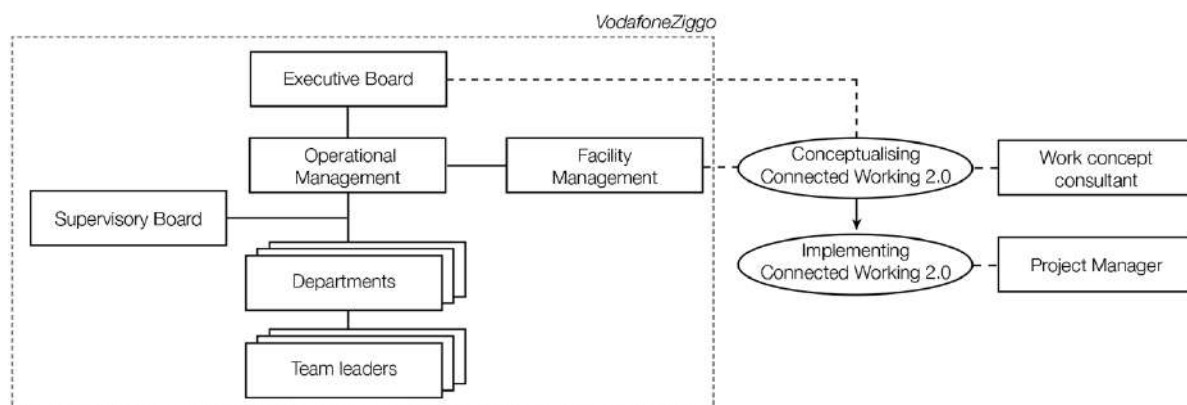

Figure 29: Organisation chart of organisation and stakeholder connections during the transition of HUB50 (own illustration based on Interviewee D & Nederlandse Politie, 2021b)

#### 4.3.3 How are these characteristics used in the current workplace design?

The workplace in question is VodafoneZiggo's headquarters in Utrecht: Utrecht Central Office. It was built in 2018 to accommodate 1600 employees. Not only would this workplace be an office, but also a showcase for the connectivity and innovation of the organisation (interviewee B). The office invites clients and customers to experience exhibited technology and games. This innovation is also intertwined in the office part. The firm wants to stimulate productivity, wellbeing, and creativity by, for instance, creating informal meeting spots and playful brainstorming areas and combining exercise equipment with workspaces. The use of dynamic and bright colours, multifunctional furniture and various types of relaxation rooms further contribute to increased physical and behavioural productivity (interviewee K).



Figure 30: Playful interactions in Utrecht Central Office by showcasing technology (Business Insider Nederland & VodafoneZiggo, 2019)

The goal of creating an attractive and collaborative office had succeeded. It became so popular that it exceeded its occupancy limits in pre-Covid times (interviewee L). The agile scrum teams were growing in amount and size. This formed part of an occupancy problem: scrum teams sporadically meet in large groups in the office and use a lot of space relative to a standard working employee. Therefore, occupancy management became a big challenge (interviewee L).



Figure 31: Activity-based working at Utrecht Central Office (Du Prie, 2019)

To tackle this problem, management developed the work concept connected to working 1.0 (Interviewee J). This concept focuses on condensing real estate to increase cross-functional collaboration and interaction. This concept was supported by a hybrid way of working, indicating

employees to work from home 30 per cent and in-office 70 per cent of the time. This would reduce the overall occupancy and increase employee flexibility (interviewee L).

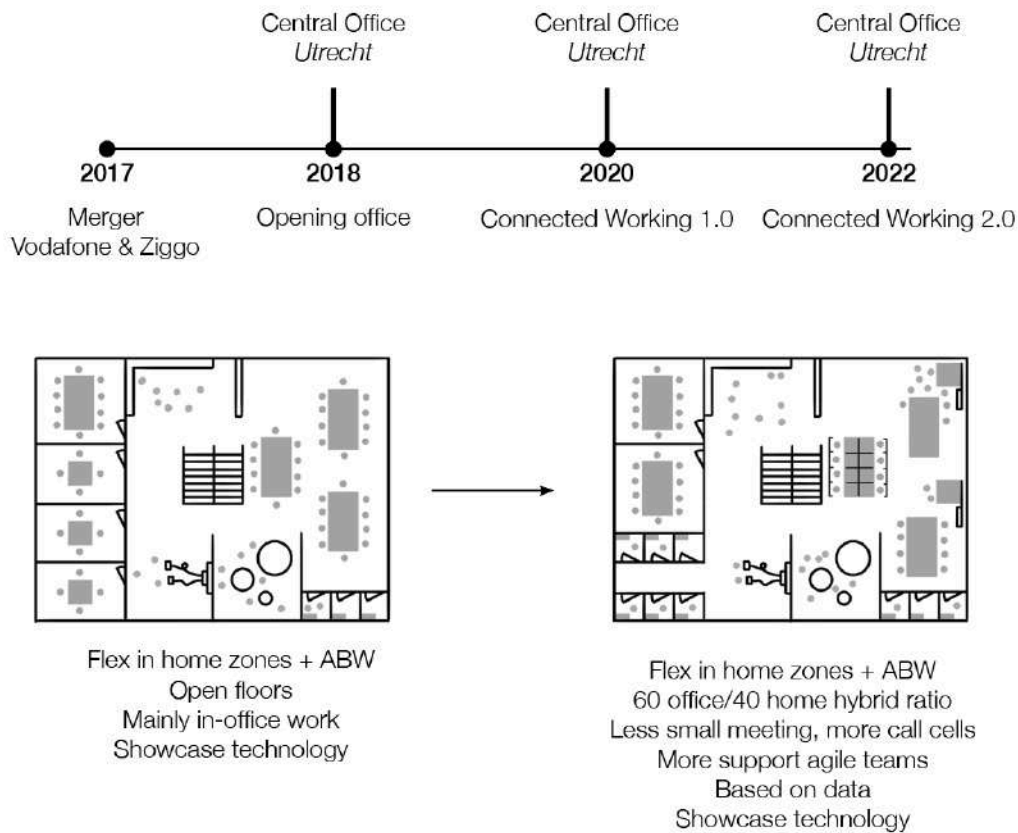

Figure 32: Location and floor analysis of HUB50 (own illustration based on floor plan analysis)

#### 4.3.4 Based on which organisational characteristics are decisions made in the transition to a hybrid workplace? And how are these reflected in the design solutions?

During the Covid pandemic lockdowns, VodafoneZiggo saw an opportunity (interviewee J; Interviewee K; Interviewee L). Over time, employees got increasingly used to home working during the lockdown. They adjusted their lives to it (Interviewee K). Office use data collected pre-lockdown and during lockdown showed the possibility of implementing more home working in the general work strategy. This could further complement the goal of the connecting working 1.0 strategy. As a result, connected working 2.0 was created, in which employees would work at home for 40 per cent of the time.

Management then hired expert advice from architects and consultants to help them find suitable design solutions for this new strategy. However, as no large intervention at the Central Office needed to be performed, the partnership with the architect did not continue. Instead, a workplace strategy firm was consulted, which would translate the collected data to a new layout (Interviewee K).

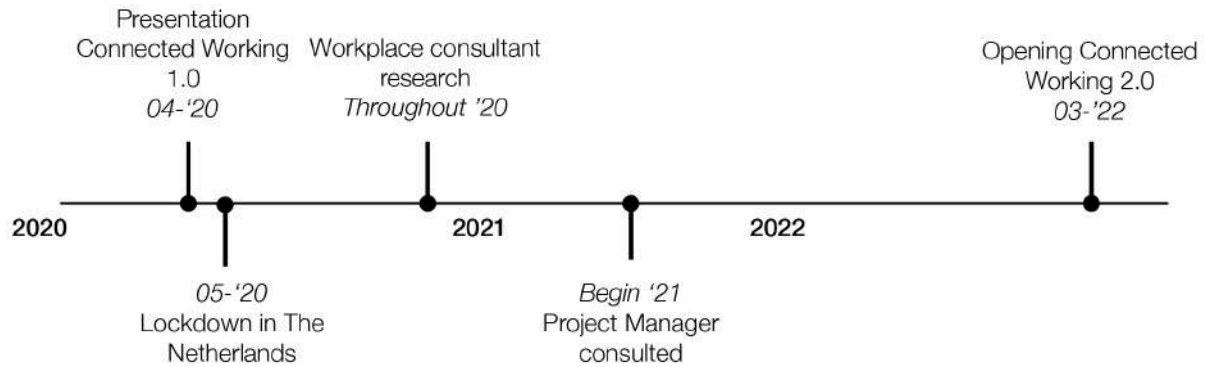

Figure 33: Timeline renovation of Utrecht Central Office

Once the lockdown was over, employees would want to head back to the office, VodafoneZiggo concluded. The offices would have to be altered from connecting working 1.0 to 2.0 before the end of the lockdown. This way, the firm could use the momentum of Covid, as employees were still used to home working (Interviewee J; Interviewee K; Interviewee L). Another decision was made regarding areas of another office outside of Utrecht. Floors would partially or completely be put on 'black' or 'white'. Black means completely shutting down office space and awaiting a planned divestment of real estate. White practically means doing the same. However, this office space can, for some reason, not be divested. The reason to do the latter is mostly for change management. Employees would then understand the changes of connected working 2.0 (Interviewee J).

The firm also decided to consult a project manager. Together with the workplace strategy advisor, further research on employee needs and activities was performed. In this research, employees were categorised into four personas. Each persona was connected to certain activities and several hours spent in-office and working from home. These hours combined added up to 40 per cent of home working in connected working 2.0 (Interviewee L).

This change was translated into more stand-up spots in the same room as individual working spaces. This was to support the scrum teams, who would gather now and then. The room for these meeting spaces was realised by reducing the number of small meeting rooms, as these meetings would happen in teams. This meant that the individual working spaces would have to be more soundproof so that multiple employees could call in the same room simultaneously. The desks were therefore equipped with sound insulating walls.

Mostly, changes are seen in the layout, type, and amount of office furniture. The fit-out of the building was not changed, as collaboration, creativity and innovation are already sufficiently supported (Interviewee J; Interviewee L).

#### 4.3.5 Discussion

Unlike the outdated, old-fashioned fit-out the other cases experience, VodafoneZiggo's current workplace is modern, flexible and focuses on connectivity and showcasing technology. However, the workplace *underperforms in terms of* being overcrowded. This issue was proven by data on office use VodafoneZiggo is constantly collecting. As the organisation's mission is to make fun

and progress with every connection, it is constantly looking for ways to improve employee *productivity* and wellbeing.

In the second phase, the research and the data are translated to which *processes* need to be supported in the future workplace. In collaboration with workplace experts and project managers, requirements are set up. A higher flex factor with more support for agile team activities fits the needs and preferences of the employees.

During the pandemic lockdowns, the organisation’s employees have gotten used to working from home. The manager’s task is to attract employees back to the hybrid office. The success of this task is yet to be measured.

**Common components experienced by stakeholders in transitions to hybrid workplace**

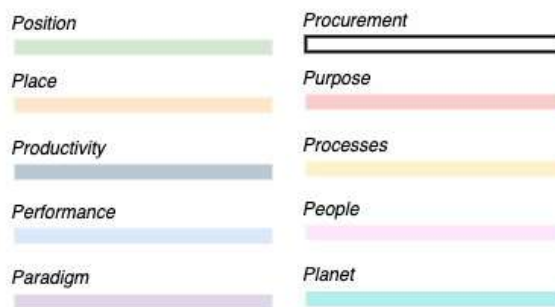

**Vodafone/Ziggo**

Transition to hybrid workplace

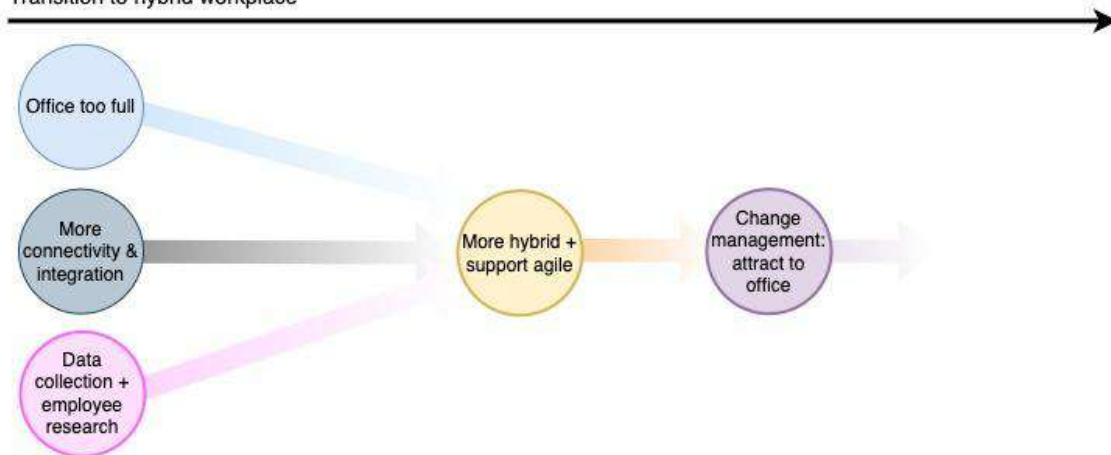

Figure 34: The visualisation of phases and use of organisational characteristics in the renovation of Utrecht Central Office (own illustration based on Haynes et al., 2017)

---

# Part 4: Synthesis

## 5. Cross-case Analysis

The findings of each case are cross-examined to find differences and similarities between the use of organisational characteristics in the three cases. This way, the research moves closer to a general understanding of the use of organisational characteristics in the transition to a hybrid workplace. The same sub-questions as in chapter 4 will be assessed but comparatively.

### 5.1 With which characteristics can an organisation be described?

Figure 35 shows how each data source perceives or reflects the use of organisational characteristics.

#### Difference

The three organisations differ from each other. For Clifford Chance, the organisational purpose seems to be the best. This is translated into the key driver of distinguishing themselves from the competition by attracting the best lawyers and providing high-quality workplaces. The Dutch Police does not have the resources to implement such a strategy for its real estate portfolio. However, because their purpose and position are so different, they do not need to be the best in the market. VodafoneZiggo seems to look more inwards than to the competition compared to Clifford Chance. This organisation's purpose is to provide connectivity to employees and clients.

#### Similarities

Apart from the clear difference in market position and organisational purpose, there are similarities between the organisations. For instance, all organisations thrive for 1) innovation and 2) connectivity. Even though these two key drivers are currently not fully achieved, they are mentioned as key drivers.

	Case 1: Clifford Chance	Case 2: Nederlandse Politie	Case 3: Vodafone/Ziggo
Project Manager	<ul style="list-style-type: none"> <li>- State-of-the-art appearance</li> <li>- Best advice, best clients</li> <li>- Hierarchical</li> </ul>	<ul style="list-style-type: none"> <li>- Complex organisation</li> <li>- Key drivers: Innovation, flexibility, sustainability</li> </ul>	<ul style="list-style-type: none"> <li>- Connectivity as product and culture</li> <li>- High-cost control</li> <li>- Innovative and use of smart technologies</li> </ul>
Organisational manager	<p>Manager 1:</p> <ul style="list-style-type: none"> <li>- At the top of the market</li> <li>- Performance &amp; cost control from executive board</li> <li>- Horizontal work culture</li> <li>- Distinguish with location and ambiance</li> </ul> <p>Manager 2:</p> <ul style="list-style-type: none"> <li>- Best at solving complex problems</li> <li>- High amount of collaboration</li> <li>- Attractive for client</li> <li>- Distinguish with appearance and location</li> </ul>	<ul style="list-style-type: none"> <li>- Complex organisation</li> <li>- Slow change</li> <li>- Cost control</li> <li>- Innovation</li> </ul>	<ul style="list-style-type: none"> <li>- Connectivity and innovation</li> <li>- Supportive of employees and activities</li> <li>- Young attractive &amp; diverse appearance and culture</li> <li>- Hierarchical</li> </ul>
Architect	<ul style="list-style-type: none"> <li>- Innovation</li> <li>- Best of the best</li> <li>- Attraction new talent</li> </ul>	<ul style="list-style-type: none"> <li>- Complex</li> <li>- Traditional &amp; political</li> <li>- Accessible and serviceable</li> </ul>	<ul style="list-style-type: none"> <li>- Connectivity &amp; collaboration</li> <li>- Corporate culture</li> <li>- Organic collaboration</li> </ul>
Employee	<ul style="list-style-type: none"> <li>- Distinguish with unique location</li> <li>- Distinguish with informal culture</li> <li>- Distinguish with less hierarchical</li> </ul>	<ul style="list-style-type: none"> <li>- Political &amp; hierarchical</li> <li>- Slow change</li> <li>- Poor managerial oversight</li> </ul>	<ul style="list-style-type: none"> <li>- Transparent and open towards each other</li> <li>- Output focussed</li> <li>- Innovative and progressive</li> </ul>
Floor plans	<ul style="list-style-type: none"> <li>- Unique location of office</li> <li>- Formal appearance</li> </ul>	Previous floor plans unavailable	<ul style="list-style-type: none"> <li>- Connection employees</li> <li>- Open floor plan with mostly small meeting rooms</li> </ul>
Internal reports	<ul style="list-style-type: none"> <li>- Early expert advice</li> <li>- Long-term strategy</li> <li>- Innovative technology</li> <li>- Attraction and Retention</li> <li>- Five-star client experience</li> <li>- Unique Identity</li> </ul>	Internal reports unavailable	<ul style="list-style-type: none"> <li>- Wellbeing employee</li> <li>- Inviting clients: showcase</li> <li>- Dynamic</li> <li>- Connectivity</li> <li>- Informal meeting &amp; relax spaces</li> </ul>

Figure 35: Cross-analyses of how the organisation is described by each source (own illustration)

## 5.2 How are these characteristics used in the current workplace design?

Figure 36 shows how each data source perceives or reflects the use of organisational characteristics within its transition.

	Case 1: Clifford Chance	Case 2: Nederlandse Politie	Case 3: Vodafone/Ziggo
Project Manager	<ul style="list-style-type: none"> <li>- Attractive location for clients</li> <li>- State-of-the-art workspaces and high-tech technology</li> <li>- Informal appearance to attract young talent</li> <li>- Building insufficient, little collaboration, bad climate, unattractive, closed, no meeting spaces: unaligned</li> </ul>	<ul style="list-style-type: none"> <li>- Agile scrum teams work in team sports</li> <li>- Partly hybrid workplace strategy</li> <li>- Real estate reduction organisation-wide</li> </ul>	<ul style="list-style-type: none"> <li>- Showcasing technology</li> <li>- Open floor plan</li> <li>- ABW</li> </ul>
Organisational manager	<p>Manager 1:</p> <ul style="list-style-type: none"> <li>- Informal appearance of office</li> <li>- Partners worked in rooms with team of 2-6 people for communication and learning</li> <li>- Workplace unaligned with strategy: outdated</li> </ul> <p>Manager 2:</p> <ul style="list-style-type: none"> <li>- Image is reflected by the unique location</li> <li>- Underperforming informal meeting space; important for cross-functional collaboration,</li> <li>- People locked up in office due to assigned rooms</li> </ul>	<ul style="list-style-type: none"> <li>- Low quality real estate in general</li> <li>- Partly hybrid workplace strategy</li> <li>- In need of renovation, slow changes</li> </ul>	<ul style="list-style-type: none"> <li>- More and more agile teams</li> <li>- Diverse layout with inspiring spaces to make connections</li> <li>- Insufficient space for individual meetings and scrum teams</li> </ul>
Architect	<ul style="list-style-type: none"> <li>- Workplace unaligned with corporate strategy: too old-fashioned</li> </ul>	<ul style="list-style-type: none"> <li>- Basic fit out, does not offer much to employees</li> <li>- Insufficient office for scrum teams</li> </ul>	<ul style="list-style-type: none"> <li>- Organic collaboration translated to dynamic, diverse open floor plan</li> <li>- Capacity too low</li> </ul>
Employee	<ul style="list-style-type: none"> <li>- Juniors learn from seniors in assigned rooms</li> <li>- Little cross-functional collaboration</li> </ul>	<ul style="list-style-type: none"> <li>- Agile scrum teams in open floor plan or large team rooms</li> <li>- Insufficient office equipment</li> <li>- Insufficient IT-network</li> <li>- Employees rather work home</li> <li>- Building not inspiring and outdated</li> </ul>	
Floor plans	<ul style="list-style-type: none"> <li>- Cellular office layout</li> <li>- Assigned rooms for partners + 1 to 5 employees</li> <li>- Local coffee corners</li> <li>- Library in atrium</li> <li>- Closed, controlled client routes</li> <li>- Little cross-functional collaboration</li> </ul>	<ul style="list-style-type: none"> <li>- Open plan layout &amp; Team space floors</li> </ul>	

Internal reports	<ul style="list-style-type: none"> <li>- Restaurant and informal meeting spaces underused</li> <li>- Insufficient brainstorm and collaborative rooms</li> <li>- Insufficient rooms for private calls</li> </ul>	Internal reports unavailable	- Fit out sufficient, capacity insufficient
------------------	---	------------------------------	---

Figure 36: How organisational characteristics are reflected per data source (own illustration)

### Performance unalignment as an incentive

Multiple stakeholders in all three organisations indicate that one or more of their organisational goals are not being met by the current workplace. Once the transition began, this unalignment of performance became a key driver. However, the start of the transition was instituted by an external factor or deadline: the momentum of the Covid lockdown (Dutch Police and VodafoneZiggo) or an ending lease contract (Clifford Chance).

### Purpose office

In all cases, the purpose of the office within the organisation has changed significantly. One of the goals of all three organisations is to create more collaboration and connectivity between employees and increase the accommodation of team activities. Even though all three hybrid offices provide concentration spots for employees who would rather work in-office, most individual activities are presumed to be performed at home. A workplace expert summarised this during an interview: “At home, an employee has everything except for their team” (Interviewee L). The purpose of the office has thus moved away from being a place where all activities take place and have become a hub for maintaining and making new connections, making important decisions with one’s team and having informal and unexpected meetings together.

### 5.3 Based on which organisational characteristics are decisions made in the transition to a hybrid workplace? And how are these reflected in the design solutions?

Figure 37 shows how each data source perceives or reflects which organisational characteristics are used to make decisions in the transition and how these are eventually reflected in the design solutions.

	Case 1: Clifford Chance	Case 2: Nederlandse Politie	Case 3: Vodafone/Ziggo
Project Manager	<ul style="list-style-type: none"> <li>- Ending lease contract</li> <li>- Constantly evaluating future goals</li> <li>- Realigning workplace with corporate values: more attractive appearance and better support productivity</li> <li>- More connection by activating atrium and staircases</li> <li>- ABW, flexing in home zones and hybrid to accommodate cross-functional collaboration</li> </ul>	<ul style="list-style-type: none"> <li>- Organisation-wide cost cut</li> <li>- More integral and flexible working: organisation-wide ABW, hybrid and real estate reduction &amp; densification</li> <li>- Even more hybrid due to preference of employees</li> <li>- More connectivity and transparency</li> <li>- Multi-functional shared spaces</li> </ul>	<ul style="list-style-type: none"> <li>- Overcapacity office</li> <li>- Organisation-wide cost cut</li> <li>- Support agile teams more</li> <li>- Data used for calculation amount of hybrid</li> <li>- Mean and Lean real estate reduction</li> <li>- Densification of office (change management)</li> <li>- Fixed fit out sufficient</li> </ul>
Organisational manager	<p>Manager 1:</p> <ul style="list-style-type: none"> <li>- Align appearance better with informal culture</li> <li>- ABW and open floor plan to stimulate cross-functional collaboration</li> <li>- Brainstorm and call cells for connectivity and flexibility</li> <li>- Atrium multifunctional meeting place</li> <li>- Desks unassigned</li> <li>- Shift paradigm difficulties</li> </ul> <p>Manager 2:</p> <ul style="list-style-type: none"> <li>- Implement high-end technology to support flexible work</li> <li>- More connectivity in restaurant and coffee bar</li> <li>- Organising of routing and informal meeting</li> <li>- Hybrid aligns with flexible corporate DNA</li> <li>- Densify area supporting collaboration</li> </ul>	<ul style="list-style-type: none"> <li>- More efficiency, better connectivity, and collaboration: combine offices into one</li> <li>- Employee research points out possibility of high flex-factor</li> <li>- Hybrid concept makes place for innovation hub for showcasing design and technology</li> <li>- In-office workdays mainly for collaboration</li> <li>- Open floor plans with mainly small meeting rooms and call cells.</li> <li>- Smart apps to reserve</li> </ul>	<ul style="list-style-type: none"> <li>- Research to fit for purpose to support needs employee</li> <li>- Research pointed out four personas</li> <li>- More cross-functional collab: densification in real estate (reduction footprint)</li> <li>- Change in office spaces: more team meetings and (private) individual work spots</li> <li>- Momentum Covid: employees used to homework: higher flex-factor</li> <li>- Flex in home zones</li> <li>- Smart apps to reserve</li> </ul>
Architect	<ul style="list-style-type: none"> <li>- Vitalize atrium for connectivity</li> <li>- Create an experience</li> <li>- Stimulate cross-collaboration by routing</li> <li>- Daring, young, and attractive appearance with furniture and</li> </ul>	<ul style="list-style-type: none"> <li>- Based on scrum activities: more stand-up, whiteboards, small meeting rooms</li> <li>- Diversity of colour and furniture to inspire</li> </ul>	<ul style="list-style-type: none"> <li>- Creating personas to research office needs</li> <li>- Support changing work style more (IT to corporate; individual to agile teams): more large team spots</li> </ul>

	colour increasing comfort and supporting war on talent - Environmentally and cost wise unsustainable building	- More glass walls to represent transparency - Shared spaces are comfortable and attractive, but also functional	- Organic team concepts to create cross-functional collaborations - Backed by data: change management
Employee	- Senior and junior not in assigned rooms anymore - Insufficient number of desks - Paradigm shift up to now unsuccessful	- Employee research with surveys, meetings, and scrum boards - Ambassador roles created for change management - Hybrid supports preferences employees	
Floor plans	- 11% area reduction - No assigned rooms, but assigned home zones - Smaller meeting spaces (average) due to addition of brainstorm rooms - Fully ABW 3rd floor	- Ground floor semi-public for visitors and meetings - 1st, 2nd, 3rd floor less public for users, open floor plan - Small meeting rooms, call cells	Floor plans unavailable
Internal reports	- Innovative technology - Enabling Workstyles - Attraction and Retention - Five-star client experience - Unique Identity	Internal reports unavailable`	- Data collected previously - New research towards personas - Calculated office needs - Flex-factor accommodates office needs

Figure 37: The use of organisational characteristics in the transition and how these are eventually reflected in the design solutions (own illustration)

### Incentive transition

In two cases, the organisation had been aware of an underperforming workplace for quite some time: Clifford Chance and Dutch Police. In the case of Clifford, the building interior and office equipment were outdated, written off and aesthetically unpleasing. Management had been aware of this for years, as early research performed four years before the renovation pointed this out. The ending of the lease contract was, however, seen as the deadline for the transition, not the underperforming office.

In the case of the Dutch Police, the offices are mostly basic. Even though management is aware of this, changes in real estate happen slowly due to the firm's complexity, political and public nature, and cost-cutting goals.

Unlike the two above, VodafoneZiggo tackles its real estate problem almost immediately. Their office opened in 2018 and was renovated during lockdowns between 2020 and 2022.

### Densification offices

The findings of all cases mentioned the densification of real estate. This goes well with a hybrid workplace, as more space is freed when employees work partially from home. In all cases, this densification is both a consequence of closer collaboration of employees physically to improve cross-functional collaboration and a consequence of cost control.

## Expert Advice

All organisations turn to expert advice early in the transition to assist them with translating their key drivers into requirements and these requirements into design solutions.

## Transition phases

After the above incentive of the transition towards a hybrid workplace, all organisations begin researching employee needs, preferences, and activities. The results of this research are then, in one way or another, combined with the organisation's key drivers to create the requirements for the hybrid workplace.

At Clifford Chance, the employee research results pointed out the preference for a diverseness of spaces, more connectivity, and a better appearance. This was combined with the firm's drivers to produce the best advice in the market, for the best clients, provided by the best lawyers, and to have a distinguishing (informal) appearance and stimulate cross-functional collaboration. This resulted in multiple requirements of the hybrid office: a transparent, modern, and informal appearance, activation of staircases and the atrium and flexible, open work floors.

At the Dutch Police, the employee research results pointed out the preference of working more hybrid. This was combined with the firm's drivers to integrate and connect its workforce, showcase its technology and innovation, increase flexibility, and cut costs organisation-wide. This resulted in densifying the real estate portfolio and increasing the building quality and cross-functional collaboration HUB50 specifically, resulting in the requirements of being a flexible multi-functional building with space for visitors and employees in which people feel welcome, and innovation can be showcased.

At VodafoneZiggo, the collected office data and employee research pointed out the increased preference for home working, more individual video conference spaces and more support for agile team activities. This was combined with the organisation's drivers being connectivity for employees and clients, having a young, attractive, and flexible appearance and using technology to improve constantly. This resulted in the requirements of the hybrid working being more stand-up and meeting areas for the agile teams, a higher flex factor, and more call cells.

## Change management

All organisations have implemented change management tools to support the hybrid offices and the transition towards this. Clifford Chance created a housing committee, translating the partners' wishes and publicising and marketing the idea of hybrid working. This group consists of partners who ought to set an example of, for instance, the clean desk policy. VodafoneZiggo and Dutch Police provide applications employees can use to reserve meeting rooms. However, all interviewees experienced change management as incomplete and lacking by at least one in each case. A clear long-term policy towards change management was not perceived.

## Paradigm shift

The organisations either have the incentive to undergo a paradigm shift towards a more flexible working culture or are already in that transition. Clifford Chance wants to distinguish itself with a unique location and daring, young and flexible workplace. The decision was made to step away

from a cellular workplace with spaces assigned to partners and move towards a flexible and hybrid office that supports more collaboration.

This shift from a standard and traditional law firm layout and work culture to a flexible, modern organisation reflects the appearance goals of the firm. Their new hybrid workplace, the shift away from traditional work forms, can also be seen in the Dutch Police. Whereas most buildings in their portfolio are basic and ordinary cellular offices, the HUB50 will showcase a new workplace norm and set the bar for future developments.

VodafoneZiggo is the furthest in this paradigm shift. Since its merger in 2017, the firm has been working increasingly with agile scrum teams reflecting the transition from an IT firm to a corporate. The renovation of Central Office Utrecht and the new work concept that comes with it further support the shift towards more flexibility.

In other words, the perspective of the organisations on paradigm is not used and reflected in the transition to their future workplace. Still, the future workplace is used to support their views on the organisational paradigm.

#### Level of flexibility

All three hybrid workplaces are also flexible in terms of workspace. This means that employees who work in-office are flexible to sit where they want. However, all organisations restrict (1st and 2nd floor Clifford Chance & Dutch Police) or guide (VodafoneZiggo) this flexibility by implementing home zones. A home zone is a part of the office assigned to a team (Interviewee C). Within this home zone, a team is free to choose any available desk.

All three cases also have a part of the building with complete workspace flexibility, either an activity-based working area (3rd floor Clifford Chance, ABW area VodafoneZiggo) or a multi-functional space (atrium Clifford Chance, atrium Dutch Police). However, at least one interviewee per case indicates that 'realistically', employees mostly return to their 'favourite' spot.

#### Planet

All ten components have been mentioned during interviews at least once in each case, except for one. The component planet was never mentioned during all five interviews with Clifford Chance participants.

## 6. Discussion with literature

The cross-case analysis provides a comparative discussion of the results of the case studies. These results have been produced by using an existing corporate real estate management model as an instrument. Therefore, are not only the results themselves useful to compare and discuss, but also the connection between the results and the model.

### 6.1 Introduction

The model used is the 10P model by Haynes et al. (2017), described in chapter 2.2. The model categorised each organisation into eight components that produce two strategic outputs when aligned properly. The authors aim to define these ten organisational characteristics, presenting a real estate (asset) manager with a clearer overview of the complex workplace. These ten definitions have been used in this research to categorise and code phases and choices of real estate managers in the case studies.

The second goal of the model is to provide real estate (asset) managers with an overview of how to align these characteristics properly. The book in which the model is presented can thus be seen as a long checklist of procedures the manager must perform before alignment can be reached.

This chapter compares the steps of these aligned procedures defined in the literature with those performed by real estate managers in the case studies. This shows the similarities and differences between managerial procedures in literature and the field, which are then discussed. This chapter aims to understand which of the recommended procedures within the 10P model are performed by the real estate managers during the transition to a hybrid workplace. And if not by the manager, then and by who. Also, this information serves as a start of the reflection on the 10P model as part of the research method.

For further quantitative analysis, the alignment procedures of each organisational characteristic recommended by Haynes et al. are numbered, shown as (1) [*procedure*]. If this procedure is performed by the real estate manager active during the transition of the case study, it will be coded with a coherent number. If the procedure is not performed, the number is left out.

The results point out that managers often outsource the procedure or perform the procedure in collaboration. Therefore, a further distinction is made between stakeholders engaged in the procedure. If the procedure is not performed by the real estate manager but by another internal or external stakeholder, the number is followed by an X, for example, 1X. If the manager performs the procedure in collaboration with another stakeholder, the number is followed by a C, for example, 1C. If the procedure is not performed, it is shown as 1/.

## 6.2 Findings

### 6.2.1 Position

#### Definition in literature

This characteristic describes the position of an organisation in its market, providing the context in which long-term decisions are made (Haynes et al., 2017).

#### Procedures in literature

The steps the authors advise managers to perform are (1) assess and compare internal strengths, and weaknesses with external market factors, (2) create multiple scenarios to analyse the future-proofness of the current real estate, and (3) create an action plan to prepare for the possible future changes.

#### Usage in the transition per case

Case 1: Clifford Chance's executives and real estate managers were aware of the threat that their underperforming workplace would eventually negatively affect their organisational strengths and opportunities. This resulted in a workplace transition plan in which the new workplace would (1C) mitigate internal weaknesses (poor routing, little informal communication, low attractiveness) and threats (employee and client attrition, loss of market position) as well as respond to external factors (technological development to support hybrid work) and the changing needs of the current and future generation of the workforce (the preferences of hybrid work, the physical office as a place for community and collaboration). External advisors (2X) performed a location analysis, identifying the best fitting location to implement the plan. The real estate managers, project managers and architect then (3C) created an action plan to execute the plan. An action plan regarding change management or the home office is not yet created.

Case 2: Higher management in the Dutch Police has identified the need to cut real estate costs as well as upgrade real estate quality organisation-wide by (1X) reacting to key developments in the market (technological developments and demand for environmental sustainability) With this change, the organisation will position itself better in a market of fast-paced criminal activity, employee retention and attraction and sustainability goals. The real estate manager performed, together with The HUB50, was then acquired to house this change. (2/) The real estate manager active during the transition was not part of this procurement process. The real estate manager creates a transition plan with the architect and project manager. The focus is on creating a flexible workplace to set the new norm of future-proof workplaces within the organisation (3C).

Case 3: The telecom provider VodafoneZiggo is constantly reacting to and positioning itself in markets concerning connectivity. Both higher management and facility realised their organisation's strength of connectivity and the use of technology was changing into a weakness due to an overcrowded workplace. The momentum of Covid created an opportunity to save costs in real estate organisation-wide. (1X) A new plan was created to densify real estate whilst increasing the flex-factor. (2/) An external architect created multiple tailored workplace design scenarios but was not pursued, and the collaboration was stopped. The real estate manager and

the project manager (3C) create an action plan for the transition. The real estate manager predicts another future change that further increases the flex factor, but no action plans are made.

### Conclusion

The component position is embedded in the core values of the three organisations. In all cases, higher management and real estate managers are aware of the organisational strengths, weaknesses, opportunities and threats, the organisation's position in the market and the external factors influencing these two. In a transition to a hybrid workplace, the organisation's position is translated early on into the core values and goals of that change, often by higher management or the real estate manager together with higher management. The cases do not show a clear scenario study. When it occurs, external advisors perform this task, not the real estate manager. The action plan for the transition was the only one identified. There are no concrete action plans for other possible future changes.

This shows that during a large change in real estate, such as that in the case studies, the real estate manager is aware of the internal and external position of the organisation but will always make decisions regarding position in collaboration with other stakeholders. The real estate manager is often a translator between employer, employee, and advisor in this decision-making process. Haynes et al. mention this passive role real estate managers often have and point out that a change in organisational structure is needed to solve this, for example integrating real estate managers more in higher management and vice versa (Haynes et al., 2017).

## 6.2.2 Purpose

### Definition in literature

The driving forces of an organisation, its long-term strategy and corporate culture are all captured in the characteristic purpose (Johnson et al., 2008). It considers an organisation's vision, mission, and purpose, complementing the previous characteristic position (Haynes et al., 2017).

### Procedures in literature

According to the authors, a real estate manager must understand an organisation's corporate strategy and integrate it into corporate real estate asset management. The main steps taken to achieve this are (1) Identifying the beliefs, values, and goals of the organisation, then (2) considering how the current and future ICT, human assets and company identity can be integrated into future strategic plans. The next step is to (3) identify which corporate strategies are significant in the organisation, assess if the current and future workplace supports this create a plan to optimise this.

### Usage in the transition per case

Case 1: During the interviews, (1) the employer and employees all seamlessly list Clifford Chance's values and beliefs. (3C) The real estate strategies regarding the future were created early in the transition by the partner and the real estate managers, who formed the in-house housing committee. (3X) The corporate strategy decisions which led up to the real estate strategy were made by partners alone. In collaboration with workplace experts, (2C) research on the employees' preferences regarding processes, ICT and location of work was performed to be integrated into the corporate strategy and future workplace.

Case 2: The Dutch Police also (1) have clear beliefs and values, well-rooted in the organisation and its employers. However, this organisation finds itself in a position of less luxury than Clifford Chance. (3X) Its real estate strategy of integrating and densifying real estate is a consequence of a large-scale cut-cost strategy. A decision is made by the real estate manager, not by higher management. However, (2C) the strategy of improving performance and productivity by increasing the quality and flexibility of real estate, and integrating the needs of the employees, was created with the organisation's real estate managers and external advisors.

Case 3: Vodafone/Ziggo's purpose, (1) its beliefs and values, are clear to employer and employee: improving connectivity between and supporting the needs of their clients and employees. Here, (2) the real estate managers have a large impact on assessing the ICT needs and integrating the human resource in the future real estate strategy, as these managers have acquired this workplace data over the years. The (3X) decision to change the real estate strategy in the first place (use Covid as a momentum to densify and cut costs) was, however, a decision made by higher management.

### Conclusion

Real estate managers know the organisational strategy, beliefs, and values. Also, they possess significant knowledge of the operational level of real estate. According to Haynes et al., this information is essential to integrate during strategic decision-making. Only then can corporate

strategy be fully aligned with corporate real estate. However, the cases point out that the real estate manager has little to no involvement in the strategic decision-making. Only once these strategic decisions should be integrated into the real estate and operational level of the organisation the real estate managers have more impact. This, just as in the discussion of Position, points toward an unaligned management structure, in which the real estate manager is not yet (fully) integrated into higher management.

### 6.2.3 Paradigm

#### Definition in literature

Paradigm is the intellectual view of how things are and work, accepted by employees and the organisation (Kuhn, 1970). The paradigm can often be seen in the identity or brand of a company, which reflects and communicates its ethos. It looks deeper into the mission, values, micro-cultures and beliefs of an organisation and its employees: the organisational DNA. All the components of an organisation's paradigm can be reflected in real estate using, for instance, layout, location, marketing, and unwritten work rules (Haynes et al., 2017).

**Procedures in literature:** The real estate manager should take several steps when identifying and integrating an organisation's paradigm characteristics into real estate. Firstly, (1) identify disconnects between organisational components of paradigm, such as mission, vision, organisational DNA and brand identity and the workplace, (2) identify the characteristics of the workplace culture and workforce and (3) create an appropriate approach to perform successful change management during a paradigm shift.

#### Usage in the transition per case

Case 1: To support Clifford Chance's strategic goals on an operational level, change management is needed. Clifford Chance distinguishes itself from competitors by implementing a flexible, hybrid, open workplace. The times of assigned rooms, traditional layouts and little connectivity are over; the future workplace will support the informal, flat culture that the firm claims to have. Even though (1C & 2C) the new workplace fits the quantitative research results towards employee workplace preferences (performed with advisors), this paradigm shift seems difficult to implement in the day-to-day activities. According to all interviewees, the (3/) current change management approach does not seem (yet) successful.

Case 2: The future users of the Dutch Police's hybrid workplace are used to a flexible work style in agile teams, and (2) employee research (performed by real estate managers) points out that this work culture is preferred. Moreover, the employees indicate that an even higher flex factor is preferred. (1 & 2) It is acknowledged that this workforce is more progressive than the rest of the hierarchical political organisation. The future hybrid workplace serves as a place that spreads this work culture and its flexibility to other parts of the organisation. On a strategic level, the future workplace itself is thus an instrument for a paradigm shift. However, on an operational level, (3/) change management methods are insufficiently preparing the future users for the future workplace.

Case 3: Since the 2017 merger, the VodafoneZiggo work culture has shifted from an IT-like firm to a corporate-like one. This paradigm shift is assisted by its relatively newly opened Central Office Utrecht, mainly by supporting the activities of agile scrum teams. (1) Due to this office not supporting the scrum teams' needs, the real estate manager identifies a disconnect between the company paradigm and real estate. The future hybrid workplace will further assist this paradigm shift by implementing scrum-supporting equipment and increasing the flex factor. (2) All decisions are based on collected workplace data, showing employee work style and preferences. Even though the office has been open for several months, it remains unclear if change management is successful, as the firm is finding it difficult to attract employees back to the office (3/).

## Conclusion

Real estate managers are aware of their employees' work styles and workplace preferences. In all cases, research is performed to identify this. However, success cannot be guaranteed when managing change within these work styles. This could have several reasons. A Clifford Chance employee thinks it is because the partners do not give the correct example. A manager from the firm points out using mostly quantitative information, such as graphs and percentages, to market the new workplace to the employees. *"The employees, however, need to feel, see and experience this change, not just see numbers"* (interviewee C). The Dutch Police attempt to provide such an experience to their employees. A 'try-out future office' was placed in one of the Police offices in Utrecht. However, all future workplace users are situated in offices elsewhere. *"Why do we as future users need to travel all the way to Utrecht to see this office? Why isn't it here in our office?"* (Interviewee I).

It seems as if real estate managers realise only too late what the impact of (insufficient) change management can be on a workplace transition. Before and during the transition, the managers are busy identifying corporate paradigm and assessing how the future workplace can support this. This is only part of the alignment process regarding paradigm. A new workplace design can support the preference for a flexible open-plan work environment or improve connectivity with new hubs *on paper*. But if the partners of that same organisation come to work and plant pictures of their children on a desk, completely ignoring the clean desk policy they vouched for (an example from Clifford Chance's hybrid workplace), the paradigm shift will never occur.

## 6.2.4 Process

### Definition in literature

This characteristic consists of all operational activities performed. An organisation's real estate must support these activities. Due to, for instance, globalisation, emerging technologies, random lockdowns, and an increase in flexibility expectations, this task is becoming more and more complex.

### Procedures in literature

To understand and eventually align the processes of their organisation, a real estate manager must (1) determine how the workplace is distributed, (2) identify and monitor and optimise the different (possible) work environment, and (3) evaluate employee mobility, interaction, and collaboration throughout the workplace.

### Usage in the transition per case

Case 1: After (1C & 2C) research focussed on the daily activities, the architect, the partners, and real estate managers at Clifford Chance decided on a combination of the hybrid concept, flexible work arrangements and an open floor plan would meet the needs and preferences of their employees. The research points out that this workplace will (3C) better support cross-functional collaboration, informal encounters, and client meetings. Moreover, Clifford is trying to change the type of processes within the organisation, from small hierarchical structured teams in closed-off spaces to larger, more agile teams working in an open, flexible office. These are all translations of the firm's purpose and position.

Case 2: The future users of the HUB50 already work in agile teams; however, the current real estate does not support the processes that fit with this. In the current office, the rooms are not large enough, the IT network does not work, and the fit-out is uninspiring and outdated. Through (1) focus groups and surveys, the real estate manager identified the needs and preferences of the future distribution of work. (2C& 3C) The architect and project manager found a suitable work environment and design.

Case 3: (1) VodafoneZiggo are aware of their employees' activities and work distribution due to extensive data collection. Using this knowledge (2), the real estate manager identified the need for more scrum-supporting equipment and an increased flex factor. This data also points (3/) out the is no need for better routing or connectivity between employees.

### Conclusion

Only in case 3 does the real estate manager perform the recommended tasks alone. Here the real estate manager heavily relies on collected data. However, this data is mostly quantitative, which may not fully show employees' needs and preferences. In the other cases, expert advisors are consulted, collecting data quantitatively and qualitatively to determine how the workplace is distributed and what the needs regarding processes are.

In all cases, the future hybrid workplace supports the needs regarding process *on paper*. However, real estate managers must acknowledge that the office is only part of the system when

implementing a hybrid work concept. The real estate manager gives the other half of the hybrid workplace far less attention. The home office must be considered equally to achieve hybrid workplace alignment.

## 6.2.5 Procurement

### Definition in literature

Procurement is the process of acquiring real estate, whether bought or leased. During this procedure, real estate managers must ensure the acquired real estate is aligned with the processes, connects with the needs of the employees, and fits within an organisation's corporate strategy (Haynes et al., 2017).

### Procedures in literature

To align the characteristic procurement with the other organisational characteristics, the 10P model recommends the following procedures. (1) Consider why the space is acquired and ensure a feasible business case. (2) Examine the (dis)advantages of leasehold and freehold, and (3) consider the flexibility and efficiency of your current portfolio.

### Usage in the transition per case

Case 1: Even though management was aware of this for years, the 20-year lease contract became a restricting factor for improving the workplace. Procurement, in the form of leasing the current workplace, was thus a restriction, an incentive and a deadline in the transition of Clifford Chance's future workplace. The real estate manager was not involved in the decision to acquire the building (or 3X sublet parts of it) but (1C & 2C) was in the decision to stay. For this decision, an external advisor calculated and presented various options. Due to the hierarchal nature of the partner structure of Clifford Chance (1X), the strategic decisions regarding the purchase or lease of real estate are made by higher management.

Case 2: The Dutch Police acquired the HUB50 to support its long-term real estate improvement, integration, and densification strategy. (1X) The real estate manager of the HUB50 was not involved in this process. Different stakeholders also perform tasks (2X) and (3X) within the organisation.

Case 3: VodafoneZiggo's real estate drivers are (3X) cost-cutting whilst (or through) integrating, connecting, and densifying. Procurement (1C & 2C) plays a large role in achieving these drivers, as the hybrid workplace reduces the real estate footprint and supports the connection of employees. Also, by putting floors 'black' or 'white' (see chapter 4.3.4), the firm used procurement as a type of change management. The real estate manager is somewhat involved in these decisions regarding real estate, but not in the initial decision to cut costs.

### Conclusion

In many procurement decisions, the real estate manager plays a passive, if not no, role. Note that Haynes et al. consider this involvement one of the many tasks of the real estate manager. This again shows the disconnect between the real estate manager and strategic decision-making, eventually causing the workplace to be less aligned.

## 6.2.6 Place

### Definition in literature

Place suggests the virtual workplace, in and out of the office, and the layout and spatial design of the latter two. Also, place can be seen as a macro factor, such as the region, country or even continent where the company is (Haynes et al., 2017).

### Procedures in literature

According to the authors, the following procedures must be taken to achieve alignment: (1) evaluate the possible locations and buildings by matching them to the organisational purpose and position, (2) consider communication strategies and change management to successfully perform a relocation of the workplace, (3) consider how the place can support the needs of people and their activities and (4) evaluate the changes during and after to measure the effectiveness.

### Usage in the transition per case

Case 1: At Clifford Chance, the real estate manager was the connection between (1X) the decision made by the partners to stay and the (3C) needs and preferences of the employees. In theory, (3) the future hybrid workplace does support all needs, as the real estate managers are very active on an operational level. (2/) Communication strategies and change management are, however, not yet sufficiently been successfully achieved. Also, the managers have a *"We'll have to wait and see how it [the hybrid workplace] performs"*, (4/) not implementing any proper measurement techniques.

Case 2: A large part of the Dutch Police real estate portfolio is outdated. (1X) The HUB50 was acquired by higher management to bring change to this issue finally. Backed by employee research performed by the real estate manager (3), this future hybrid workplace ought to support the needs of the employees finally. (2) Change management strategies are considered but are only partly effective. The effectiveness of the workplace is yet to be measured, but managers claim to have methods in place for this (4).

Case 3: At VodafoneZiggo, higher management has (1X) decided to reduce the real estate footprint, especially that of buildings not centrally located. (3) The future workplace will further support people and their activities, backed by collected data. (2) Change management and communication of this change are achieved using this data as substantiated proof. (4) This collection will continue to measure its effectiveness.

**Conclusion:** In *place*, there are different levels of decision-making. At the top, the strategic level, real estate managers are not integrated into making long-term choices. Only after this decision is made by higher management is the real estate manager activated to connect this *place* to integrate operational needs. This connection could be made much earlier in the process by involving operational needs in strategic decision-making.

Even though still not completely successful, VodafoneZiggo has the most effective method of change management to introduce the change in real estate: data. The numbers don't lie. The

organisation can use this to prove that the change is, on average, the right choice. Moreover, this method allows the real estate manager to perform the task himself. However, this method alone will not achieve good change management. A combination of data, active branding and higher management setting the example is needed.

## 6.2.7 People

### Definition in literature

This characteristic consists of the employees of an organisation, including their needs, preferences, values, personalities, cultures, and work styles. A corporate real estate manager must better understand an organisation's workforce to find a fitting office solution, thus better-aligning employees with real estate (Haynes et al., 2017).

### Procedures in literature

The procedures recommended to real estate managers are: (1) identify the different groups of employees and their workplace expectations and needs, and (2) ensure a balance in work environments to support different cultures and needs.

### Usage in the transition per case

Case 1: A key driver of Clifford Chance is the attraction, the retainment, the comfort, and the wellbeing of its employees. In the transition, (1X) extensive employee research has been performed by workplace experts, forming the key requirements for the hybrid workplace. Later, these requirements are (2X) translated by the architect into new, attractive areas that connect employees and create connecting employees and creating comfortable, informal spaces.

Case 2: The Dutch Police do not only (1) focus on the users by performing employee research but also on the needs of the visitors of the future workplace. The architect (2X) translated the diversity of needs into a diverse workplace that provides a sense of belonging for anyone who enters.

Case 3: The key driver of workplace transition for VodafoneZiggo is to create a more supportive environment for its employees. Even though the organisation has (1X & 2X) collected sufficient data on the use of the office, workplace experts are consulted to finalise the research.

### Conclusion

Employee research is essential during a transition toward a hybrid workplace. It connects directly with the research towards processes and is thus used to form requirements. However, experts are often consulted to support the manager in mapping out workplace needs. This could indicate that the recommended tasks in the 10P model are too complex for the real estate manager to perform. This will be discussed later in this chapter.

## 6.2.8 Planet

### Definition in literature

Haynes (2017) connects environmental sustainability to real estate with the concept of corporate social responsibility (CSR). This concept contains how an organisation reacts to its (local) physical and social environment and national sustainability norms.

### Procedures in literature

To ensure alignment of its *planet* characteristic, a manager ought to (1) determine if the used space is needed, as less space means fewer emissions and fewer costs, and (2) consult sustainability experts (as these measures are highly technical and complex), (3) occupy buildings with green certificates and high EPC ratings (A or B), be transparent, clear, persistent and honest about your CSR policy and (4) embrace technology to help optimise space use.

### Usage in the transition per case

Case 1: During interviews, a single stakeholder of Clifford Chance's workplace transition did not mention CSR or environmental sustainability. When specifically asked about it later, the project manager (interviewee A) recalls the improvement of the EPC being important in the location analysis decision but not a priority to the organisation. This analysis was performed by external experts (2). This is reflected in the (3/) choice of staying in the old, monumental building, which will never be close to a BREEAM certificate. The housing committee decided (1C) to sublet a part of the building to densify their real estate. The use of technology to improve space and energy use is not integrated (4/).

Case 2: The Dutch Police adheres to the governmental sustainability goals. This was used as a key driver for design during the transition to its future hybrid workplace. Also, real estate is greatly densified. The newly acquired real estate, the HUB50, is (3X) BENG, which means *almost energy neutral*. The (2) implemented an external climate specialist creates measures to achieve this. These decisions, (1X) made by higher management and the government, show the (4X) Dutch Police are actively participating in CSR. The use of smart technology will be introduced, providing (4C) the employee with an integrated virtual platform that, for instance, shows the availability of meeting rooms.

Case 3: During interviews, a single stakeholder did not mention CSR or environmental sustainability. This is due to the type of transition. VodafoneZiggo's higher management decided that only a change in layout and equipment would be performed in this office. Other (1X) VodafoneZiggo offices will be densified or sold. When the current office opened in 2018, (2) expert advice was consulted to create a green building. Technology is used to assess the use of spaces and employee activity (4). Regarding CSR, the organisation has numerous policies, activities and programs involving the community, wellbeing, and social responsibility. This is reflected in the office and shown on their website (3C).

### Conclusion

Decisions regarding the planet are often made by higher management instead of the real estate manager and then translated by external advisors into concrete measures. In these processes,

the real estate manager has little involvement and knowledge of this matter. The extent to which an organisation actively implements CSR policies differs strongly per organisation. Clifford Chance is least invested; one could even say *negatively* invested since they choose the location analysis's oldest and least efficient building. The Dutch Police follow the norms of the Dutch government. VodafoneZiggo seems to be actively invested in community and wellbeing through social and health programs. This shows that it also differs from what organisations see as being CSR.

Haynes et al. only mention consulting expert advice in this characteristic, as the tasks could often be *complex and technical*. In all other procedures of all other characteristics, the advice to seek expert advice is not listed, even though real estate managers do this for almost every procedure.

## 6.2.9 Performance

### Definition in the literature

To optimise business processes, the performance of an organisation must be measured, calculated, and benchmarked. Performance is split into two parts, efficiency, achieving the intended result with the least resources, and effectiveness, the ability to increase the result with the same resources (Haynes et al., 2017).

### Procedures in literature

Haynes et al. (2017) recommend several internal and external benchmarking approaches to organisational performance. However, only performance regarding the current and future work is considered in this research.

### Usage in the transition per case

Case 1: Internal benchmarking within Clifford Chance revealed that the Dutch office's costs and space use per employee was “very” high compared to other offices in other countries. However, other indicators show the relatively high performance of the Dutch office (Interviewee A, Interviewee B). At the same time, the disconnect between the current workplace and the values and strategy of the organisation was acknowledged. Eventually, a compromise was made, allowing the branch to stay in the current workplace if they would densify and sublet a part of it. Then, the current workplace would have to be renovated to be aligned with the company values. The real estate manager was only involved in the latter.

Case 2: The Dutch Police have struggled with outdated, uninspiring workplaces with insufficient space, equipment, and IT infrastructure. At the same time, the organisation is forced to cut costs constantly. Benchmarking the use of space in the current workplace revealed the possibility of a future hybrid workplace, as employees preferred working from home. Moving to the modern HUB50 and shifting to a hybrid workplace strategy should solve both issues, improving performance. The real estate manager was the only party involved in this process.

Case 3: VodafoneZiggo is constantly measuring and benchmarking office data. By implementing the hybrid strategy, occupancy levels will be more under control, and the agile teams will be better supported, improving effectiveness. This measure is fuelled by the measure of office space densification, which improves organisational performance by reducing real estate costs.

### Conclusion

The organisations undertake action in the form of a workplace transition due to a clear underperforming component within their organisation. In the three cases, this component differs. However, in all cases, higher management has decided on cost cuts and densification within the real estate portfolio before the transition. The transition does not necessarily *mask* the cost costs of the organisations, but it is used as an instrument to achieve it. During the transition, these strategic benchmarks that view real estate as a financial asset seem to be carried out by other stakeholders, the active real estate manager. The real estate manager becomes involved only when operational benchmarking, for instance, space usage, is used.

## 6.2.10 Productivity

### Definition in literature

Productivity can be measured in terms of output per employee. It can be split into two parts: productivity in the physical environment, the spatial design and indoor climate, and how employees interact and behave in the behavioural environment.

### Procedures in literature

As a strategic output, productivity can also be aligned with the workplace by (1) paying attention to the physical attributes of the workplace, such as climate control and lighting, and (2) paying attention to the behavioural ecology of the workplace (3) create a deeper understanding of the connection between the workplace and the specific wellbeing needs of the workforce and (4) collaborate with academic researchers to implement topical management practises.

### Usage in the transition per case

Case 1: Both the (1C) physical productivity (state-of-the-art technology, equipment, and furniture) and (2C) behavioural productivity (collaboration, connectivity, concentration spaces) were identified by the real estate manager and workplace expert as lacking in the current workplace. In this step, the architect has the most knowledge and influence. (3C) Management considers well-being the future workplace and offers various spots to relax, a physiotherapist, game rooms, a 'free' coffee bar and a luxury restaurant. Well-being at the home office is yet to be considered. There is (4/) no direct collaboration with academic researchers in corporate real estate (asset) management.

Case 2: Big changes will be implemented (1C & 2C) to improve the physical and behavioural productivity of the employees of the Dutch Police. Not only will they finally work with a sufficient IT infrastructure, but they will also work in a more inspiring and creative environment. These needs are mapped out by the real estate manager and translated by the architect into concrete design solutions in the future workplace. In his design (3X), the architect considers the well-being by creating innovation hubs throughout the building. A user raises questions if such an environment suits this group of workers. There is (4/) no direct collaboration with academic researchers in corporate real estate (asset) management.

Case 3: At VodafoneZiggo, (2 & 3) sufficient behavioural productivity and well-being measures are already achieved in the current workplace, whereas the issues and root of the transition lie (1) in the low physical productivity (insufficient space and equipment for the increasing amount of agile scrum team). There is (4/) no direct collaboration with academic researchers in corporate real estate (asset) management.

### Conclusion

The real estate managers map out the productivity needs during the research of people and their processes. Only in the case of VodafoneZiggo, does the real estate manager have relatively high involvement in the identification and decision-making regarding productivity. This is due to the high level of data collected and analysed within the real estate department of the organisation. In the other cases, the organisation consults external experts to do this task. After the lacking

components of productivity are identified, design solutions are created to solve them. For this, architects are consulted. In case 1 and case 2, employees have mentioned the disconnect between the chosen design solutions and the users (themselves). According to Haynes et al., this could be solved if the real estate manager decides on the design solutions or in collaboration with the architect. This does not yet take place in any of the cases.

## 6.3 Discussion

According to Haynes et al., real estate managers must constantly identify disconnections between real estate and business values. Only once these are identified and realigned properly will a workplace perform optimally. This realignment is realised by changing (parts of) the workplace. A workplace transition is thus an ideal moment to intervene and align. Of course, a transition itself could be the result of realignment procedures. For both cases, the authors of the 10P model recommend that the real estate manager execute the procedures discussed above. If the real estate managers performed all cases, each would execute 29 tasks.

### Collaboration

The following chart shows the distribution of which stakeholder if any, performs these procedures.

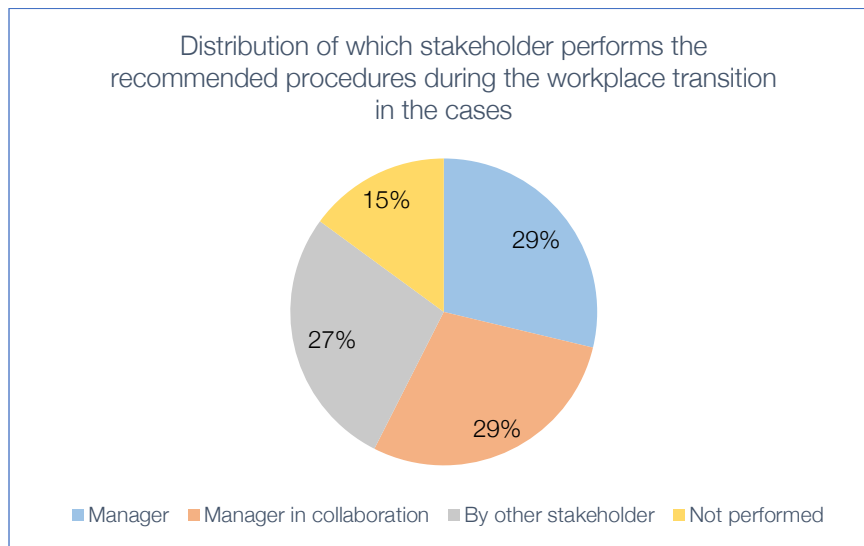

Figure 38: Collaboration and outsourcing during the execution of the recommended procedures

Notable is the number of procedures performed by the real estate manager alone. On average, only 29 per cent of the tasks recommended by Haynes et al. are executed by the real estate manager alone. In Clifford Chance's case, this was only two, and, in the cases of The Dutch Police and VodafoneZiggo, nine and fourteen, respectively. The in-house collection of workplace data allows the real estate manager of VodafoneZiggo to perform many more tasks individually than the real estate managers in the other cases. Technology to perform some managerial tasks, giving the human manager more time for other procedures. In the case of Clifford Change, this data is gathered by workplace consultants. Other differences between the managers of the cases are seen in figure 39.

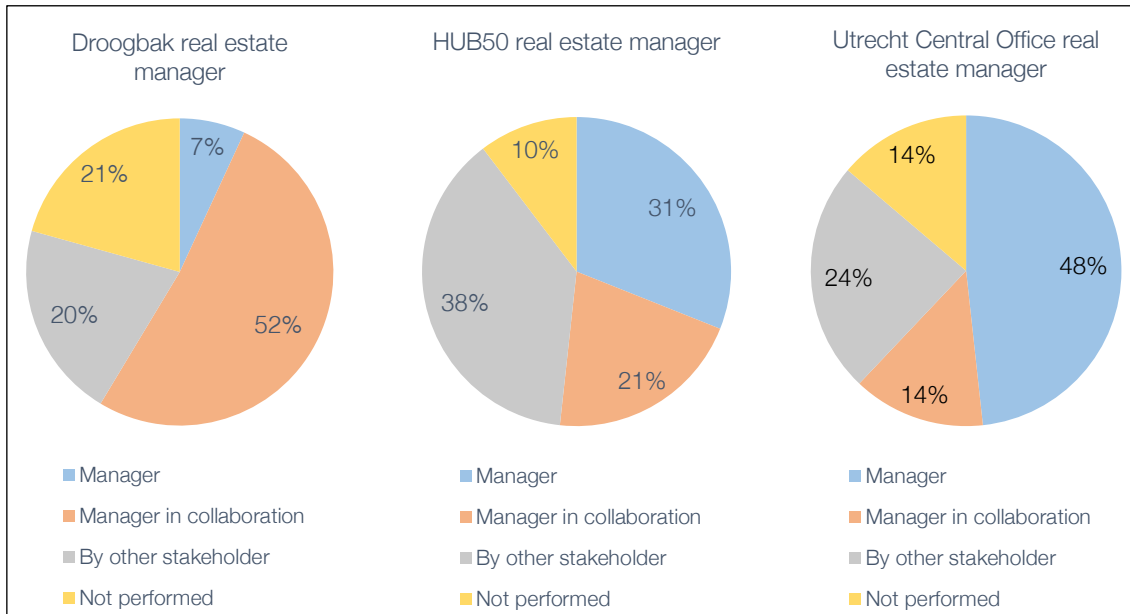

Figure 39: The recommended tasks by Haynes et al. performed by which stakeholders during the workplace transition of the cases

In another 29 per cent of the cases, the manager performs the task in collaboration with another internal or external stakeholder. A similar number of tasks, 27 per cent, is executed by another stakeholder without the involvement of the real estate manager. In other words, nearly 60 per cent of tasks are performed in collaboration with or fully executed by other stakeholders. In the literature, the authors mention consulting expert advisors *only once* in their checklist of 29 procedures they assign to the manager himself: “Don’t be afraid of purchasing expert advice” because “...the sustainability issues discussed here are highly technical and complex” (Haynes et al., 2017). This statement does come close to matching the reality. Firstly, the sustainability issues were, in fact, one of the least mentioned procedures, key drivers or requirements during the interviews. But, more importantly, many other procedures proposed are also highly technical and complex, at least when implemented during a workplace transition. The case study results show that expert advice is purchased in every step of the transition, from identifying the key drivers years before the renovation to creating a work-from-home policy a year after the transition.

Using the 10P model as a guideline or checklist for real estate managers during a transition to a hybrid workplace appears unrealistic or simply not the right instrument. Moreover, these tasks are not meant for single use. Workplace alignment is constant iteration, a continuous search for the connection between values and assets in a changing environment. However, during the case studies, the tasks are ticked off. If a manager were to perform the tasks continuously, this would cost far too much time, especially not during a workplace transition.

#### A realistic 10P model

Therefore, this research proposes a change in the model *when used in practice*. The definitions and procedures create, in theory, a clear overview of the organisational characteristics and how these can be connected. But in practice, a real estate manager cannot perform this number of tasks and their day-to-day managerial activities. The extensive use of expert advice proves the recommended procedures too complex and time-consuming for one or more corporate real

estate managers to realise alone. Also, the model expects the manager to possess various specialised skills and to use these all at once whilst staying objective and critical. This burden the model places on the real estate manager is only expected to be lightened by external expert support during one of the sustainability procedures. This research proposes expert advice to be used as a constant instrument to identify certain characteristics properly.

This change is integrated into the model by adding another P, *partnership*. This component means collaborating with experts to extract, acquire and produce more detailed, objective, and higher-quality information than the real estate manager could do alone. The partnership P is thus no organisational characteristic but a strategic instrument. Partnership is located outside of the alignment of the workplace with organisational values. Still, it can produce important information about an organisational characteristic, as seen in figure 40. Not only will this reduce the burden placed on a manager, but this will also increase the quality of information being produced and used.

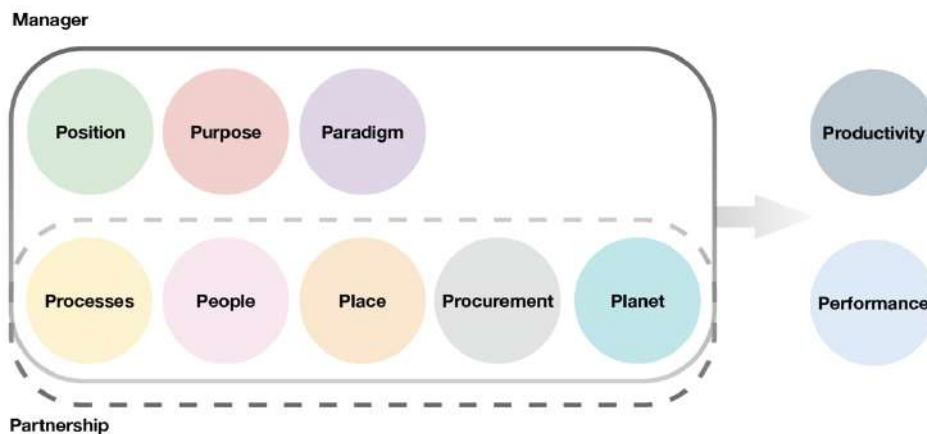

Figure 40: The addition of *Partnership* to complete the 10P model when used in practice (own illustration)

In these cases, managers have a clear overview of their organisation's position, purpose and paradigm. Expert advice is used only when tasks are performed regarding *processes*, *people*, *place*, *procurement*, and *planet*. Therefore, the redesigned 10P model shows the possibility of *partnerships* to acquire information regarding characteristics.

#### Procedures not executed

The remaining 15 per cent that is recommended is not performed at all. Two of these tasks are not executed in all three cases. These similarities are discussed below.

Firstly, the preparing of an appropriate approach for future change management. This already is shortly discussed in chapter 5.3. Managers appear to be focused mostly on the transition itself and less on marketing the future workplace to employees and the management of changing the work paradigm to fit accordingly. The consequences are clear: the Clifford Chance partners have reclaimed their fixed desk on the open-plan office with a 'clean desk' policy. The future users of the HUB50 have little to no idea what their future office design will look like because the try-out workplace is situated far away from their current workplace. And the VodafoneZiggo real estate manager is struggling to attract employees to work in their newly renovated workplace instead

of dealing with an overcrowded office. This might not only be caused by the manager's neglect but simply by ignorance; working from home is a skill. And it requires its corporate paradigm to support it. Charlie Warzel and Anne Helen Peterson write in their book *Out of Office* (2021), which critically reviews the concept of home working, that “*managers are new to home working and struggle with the same issues as the employees and their managers. The expectations are unclear, the boundaries are blurry, and the communication is poor*”. Managers must, together with representatives from every level of the organisation, invent the paradigm of the future hybrid office. New guidelines must be created in a timely process that requires transparency, experimentation, and trust (Warzel & Petersen, 2021). Otherwise, the dangers of hybrid work discussed previously will emerge.

Secondly, all three cases do not execute the procedure of collaborating with academic researchers. A good example: *all* interviewees, and *all* fifteen real estate experts (junior, medior and senior) working for the graduation organisational, were unknowing of the 10P model or the theory around it. Academic research has not yet found its way into the daily activities of the real estate manager.

#### 10P model as a research method

Haynes et al. acknowledge the different work environments: working in and out of the office and virtually. The balance between these places forms the distributed workplace of an organisation. The authors propose several procedures that focus on finding this balance by identifying the needs of the employees. However, most tasks are focused on the ‘working in the office’ environment.

For the future hybrid home office, a manager must learn to manage employee time, transfer brand identity, uphold trust, acquire the skill of working from home, create home working guidelines, remotely measure wellbeing, provide sufficient equipment, and use the hybrid flexibility to advantage and so on. This home office side of the hybrid concept is just as important as the office side, especially when we speak of alignment between components.

However, the recommended procedures of this pre-pandemic model are not yet accustomed to the amount and the extent of hybrid work that is preferred in the post-pandemic era. As this research also focuses on the physical office workplace, using the 10P model is an accurate instrument. However, it must be stressed that this only captures part of a bigger system. *The pre-pandemic 10P model does not fully capture the post-pandemic workplace.* To fully comprehend the hybrid concept, the “working out of office” and “working virtually” environments must be researched and aligned with the process described in this study. New procedures per characteristic must be added, for instance creating guidelines as discussed earlier on such as creating guidelines as discussed earlier in this chapter. Only then will the 10P model be an accurate method to analyse a complete hybrid workplace.

## 7. Conclusion

This research analyses the transition to the hybrid workplace by identifying if, and if so, how the ten organisational characteristics are used within three case studies. The discussion provides an overview of how these ten characteristics are used in the cases, assessing the differences between the cases and the definition provided by Haynes et al. (2017). This chapter identifies the key takeaway of this study and answers the main question:

*How are organisational characteristics used in the transition to a hybrid workplace?*

The ten organisational characteristics are used in four phases of the transition to a hybrid workplace. Also, findings point out that certain characteristics are commonly translated into another during this transition. With this information, a generalisation can be made.

The first phase is the realisation of an underperforming workplace. Here, the organisation identifies their views on *performance* are unalignment with the. For every organisation, this is different. The workplace either does not support the needs and preferences of the employees and their activities or does not fit the (changing) position or purpose of the organisation. Higher management and the real estate manager are aware of the underperforming workplace but do not intervene directly. The three main reasons are 1) the inflexibility of the procurement strategy, 2) the knowledge gap on improving this alignment and 3) the wait for a strategic momentum. Even though the negative performance output of the workplace and its cause are acknowledged, the organisations wait for this strategic moment to incentivise a change. In the cases, the time between acknowledging negative performance and the actual workplace transition took two, four and ten years. This moment is either ending a lease contract or implementing an organisation-wide policy.

The three transitions are also used by higher management to implement cost cuts through real estate footprint densification whilst combining the change as a performance and productivity improvement—a win-win for the organisation. The real estate manager, employee, and project manager are often not involved in the decision-making leading up to these strategic choices. To achieve more alignment during this phase, the employee and real estate managers (who possess valuable operational information) must be integrated more often in this strategic decision-making process, as the win-win for the employer is often not the same for the employee.

The second phase is the incentive phase. Once the decision is made to improve the underperforming workplace and densify the real estate footprint, the organisations immediately collaborate with external workplace advisors to help scope the project and identify the requirements. During this corporation, the organisational managers provide information on organisational key drivers: the *purpose* and *position* of the organisation. The workplace advisors use their recourses and knowledge to research employee and workplace activity. Other advisors, the project managers, are consulted to create a planning, translate needs, and create a well-functioning team of stakeholders. The organisational key drivers, combined with the research

results, provide an overview of the needs and preferences of both the employee and employer. These needs and preferences form the requirements for future change.

From this phase on, the gap becomes larger between the recommended procedures the real estate manager should perform according to Haynes et al. and the tasks they perform in practice. Many tasks are outsourced, performed in collaboration, or by another internal stakeholder. This shows the difference between what academic researchers expect of the real estate manager and what the real estate manager realistically can perform. A redesign of the 10P model is proposed, introducing the new P: *partnership*. Partnership, the collaboration with external advisors, can be used as a strategic instrument to identify characteristics more accurately and objectively. This additional component, presented in chapter 6.3, makes the 10P model more understandable and useable for real estate managers in the field.

The next step is the third phase, when the requirements are translated into design solutions. The next expert, the architect, plays the main role in this. The design must reflect the organisational drivers and the needs of the employees. With the help of the first expert, the project manager, the design is realised. The physical change is now complete. However, the transition is not.

The final step this research identifies is guiding the change physically, socially, and physiologically. The new, hybrid workplace users must understand and accept the change. A paradigm shift within the organisation also fuels all transitions. From traditional to modern, from outdated to high tech and from a tech firm to a corporate firm, all introducing more flexibility for the employee. The change management accompanying this change is mostly initiated at the end of the transition or even after completion. And even then, it remains unknown how effective this change management is. More effective alignment could be reached if guidelines and needs of the future workplace are discussed early in the process, not at the end. This process must be a discussion between all levels in the organisation. Mapping out the expectations of the home workplace is especially important, as the paradigm for this environment is still underdeveloped. If the work culture of the home office is not properly determined integrally and built on trust, the dangers of working from home will appear. The future hybrid manager must be trained to become dynamic, understanding the needs of the employees individually.

Figure 41 visualised the phases mentioned above. Within each phase, the organisational characteristic(s) on which stakeholders commonly focus is shown. The stakeholder who generally performs the tasks within this phase can also be seen. This general model summarises the answer to the main research question. Together with the recommendations this chapter describes, the discussion, and the redesigned 10P model, it can be used as a map for managers struggling with how to start their transition.

It cannot be overstated that this map *is not the magic formula* for transitioning to a hybrid workplace. Every manager must find their route. This study can be useful as guardrails during that journey by providing inspiration, presenting the possibilities and challenges of implemented transitions, and creating a method to categorise and visualise organisational characteristics.

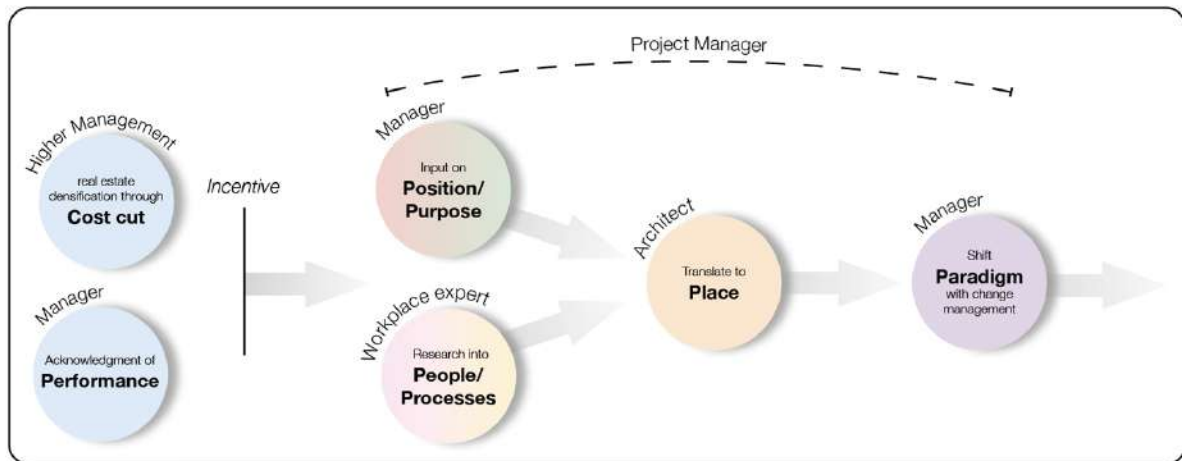

Figure 41: How organisational characteristics are used in the transition to a hybrid workplace (own illustration)

## 8. Recommendations

### Not the magic formula

The field of research into the alignment of organisational assets and organisational values is relatively new and unexplored. Even more so, research on post-pandemic workplaces has just begun. Therefore, this research should not be seen as the definitive answer to the current workplace challenges but as an inspiration, a guide for managers, and a backbone for further research. Managers must stay updated with new research and combine it with these findings.

### Aligning practical and academic work

Haynes et al. (2017) have encouraged real estate managers to collaborate with the academic world for years. This recommendation is easier said than done, as this study concludes there is hardly a connection between the real estate professional and the real estate researcher. The recommendation to keep up to date with further research will thus not cut it. It should be the responsibility of both sides to align their work. In other words, the manager should keep up to date with the academic world, but the researcher should produce models that fit the daily management activities. This research creates such a model. The 10P model was used as an instrument during the research but was found incomplete and unrealistic for practical use. Another P was added, and the model was visualised differently. Suppose these extra steps (testing the theoretical model in practice and visualising it in a suitable way for professionals) are performed for all research. In that case, the gap between the academic and practical will shrink.

### Part of a bigger system

In the introduction, this research context is demarcated several times. Firstly, only the physical workplace of the hybrid workplace is analysed. The virtual workplace, an essential part of the hybrid concept, is hardly discussed. The main reason for this is that the instrument used, the 10P model is a pre-pandemic theory. It mainly focuses on the office workplace, and the importance of the working-from-home and virtual environment is not made clear. These results are part of a bigger system, which still needs to be studied.

Secondly, this research is performed from an organisational perspective. Again, this is a part of a larger context. Even though often touched upon in this research, the employees' perspectives, needs and requirements should be researched more. Alignment can only occur when both sides of the equation are analysed in detail.

Thirdly, the results only apply to the middle to large organisations in the trades and services sector and the public sector. The model presented in chapter 7 may not apply to organisations that don't fall within these criteria.

### Validation

This research concludes generalisation for a broad segment of the offices: the trades and services sector and the public sector. According to (Yin, 2003), the more cases are used, the

more accurate the findings are. Therefore, research into cases in the same sectors ought to be performed to validate these findings.

## 9. Reflection

### 9.1 Topic Reflection

Real Estate Management (REM) is one of the three possible research themes for students of the MSc in Management in the Built Environment. This was also the name of one of the courses previously taught in this master's degree. This course introduced alignment between business values and business recourses. Like this thesis research, the 10P CREAM mode by Haynes et al. (2017) was used as an instrument to explain and analyse organisational characteristics. During this course, there was a clear connection between the spatial design of a workplace and business performance. Personally, this was the connection between management and design I was looking for. Also, it became clear that this method, the alignment of business with its recourses, is a relatively new and unexplored field. According to Haynes et al. (2017), understanding and finding this alignment is the holy grail for organisations. And it is yet to be found by managers and researchers. Based on my personal interests and societal and academic relevance, I chose this topic based on my interests and societal and academic relevance.

My graduation internship at Dev\_ real estate allowed me to investigate this topic in the field. During my research, I found that understanding alignment in the field was only starting to develop. Most managers I spoke with during explorative and semi-structured interviews were unaware of the research but found it logical, intriguing, and essential.

At the same time, seeing how managers in private and public organisations strive to create a successful workplace environment was fascinating to me. Only now do I understand truly the magnitude of corporate real estate. And this was only the tip of the iceberg.

Therefore, looking back, I feel that the area of corporate real estate (management) is an increasingly important topic. Now more than ever, with the increasing globalisation, technological advancements, and rapidly changing needs and preferences. I believe that both this and a societal understanding of current and new methods and theories regarding corporate real estate can greatly increase performance. I also imagine that the findings and conclusions in this research can provide understanding and grip to corporate real estate managers in the field. It provides a realistic and summarised overview of how organisational characteristics are used in the future hybrid workplace, something many organisations seek.

My interest in this topic has only grown during this research. I do see myself pursuing a professional career in the field of corporate real estate management.

## 9.2 Method Reflection

When reflecting on the process of this thesis research, it turned out very different than I first expected. My goal was clear, firstly, to gain practical experience in the field of real estate management, and secondly, to add useful knowledge to the field of research.

I planned to achieve this by creating a *'hybrid strategy tool'*. This spreadsheet-like tool would use collected data to create unique hybrid strategies tailored to the organisation. These strategies would, for instance, indicate which level of hybrid concept and calculate and visualise the future spatial fit-out. This would reflect my interest in both management and architecture.

After explorative interviews with creators of an existing tool, CBRE's *Hybrid Footprint Calculator*, and professors of the course Research Methods 2, a course introducing possible thesis research methods, I realised how much quantitative data would be necessary for this tool to produce realistic and representative outputs. I also feared that collecting quantitative data would not allow me to experience real estate management first-hand.

I also noticed that my research environment was too broad to analyse all aspects in-depth. In addition, finding a clear methodology that scientifically integrates management and spatial design was difficult. I thus decided to demarcate my topic by only qualitatively assessing the connection between organisational characteristics and implemented hybrid workplaces. Using case studies with interviews and floor plans as data sources, I would closely experience the practice of real estate management and its connection to spatial design.

I received the feedback not to lose sight of the employee perspective. I ensured this by adding an interview with an employee in each case and further analysing the people components in the 10P CREAM model by Haynes et al. (2017). Close to my P5, I read the book *Out of Office*, which gave me more insights into this side. I regret not having read this book earlier in the process, as integrating it more would have made the story more complete.

Receiving access to cases through an internship at Dev\_ real estate, a project manager and real estate advice organisation, was a gamechanger. Here, I was guided well by my graduation mentor Bart Rodenburg in every step of the process. All other employees were open to sharing their opinion and experiences regarding by topic. This internship thus added a lot to my research quality and understanding of the real estate practice. I would advise such an internship to anyone going through a similar thesis process.

The book *Corporate Real Estate Asset Management*, which includes the 10P model, was a good guide when exploring the different characteristics of an organisation and its office. The model does a good job at categorising and defining the extremely complex workplace. As I write in my research, however, I think this model is incomplete when studying the hybrid workplace as a whole, as the virtual and home working environment are not fully incorporated.

## 10. References

- Anitha, J. (2014). Determinants of employee engagement and their impact on employee performance. *International Journal of Productivity and Performance Management*, 63(3), 308–323. <https://doi.org/10.1108/IJPPM-01-2013-0008>
- Appel-Meulenbroek, R., & Danivska, V. (2021). *A Handbook of Theories on Designing Alignment Between People and the Office Environment*. Routledge.
- Arkesteijn, M. (2019). *A+BE Architecture and the Built Environment - Corporate Real Estate alignment* (1st ed.). TU Delft.
- Bacchi, U. (2021, January 29). *Fewer desks, more coffee: How the office could change after COVID-19*. U.S. Retrieved 16 October 2021, from <https://www.reuters.com/article/us-health-coronavirus-workers-trfn-idUSKBN29Y1O7>
- Becker, F. D., & Steele, F. (1995). *Workplace by design: Mapping the high-performance workscape*. Jossey-Bass.
- Bell, J. (2005). *Doing Your Research Project: A Guide for First-Time Researchers in Education, Health and Social Science* (4th ed.). Berkshire: Open University Press.
- Blaikie, N., & Priest, J. (2019). *Designing Social Research*. Amsterdam University Press.
- Bloom et al. (2015). Does working from home work? Evidence from a Chinese experiment. *The Quarterly Journal of Economics*, 130(1), 165-218.
- Boell, S. K., Campbell, J., Cecez-Kecmanovic, D., & Cheng, J. E. (2013). *Advantages, challenges and contradictions of the transformative nature of telework: A review of the literature*. In Proceedings of the Nineteenth Americas conference on information systems, August 15–17(pp. 1–10). Chicago, IL.
- Bon, R. (1992), "Corporate Real Estate Management", *Facilities*, Vol. 10 No. 12, pp. 13-17. <https://doi.org/10.1108/EUM00000000002218>
- Bootle, R., & Kalyan, S. (2002). *Property in Business: A Waste of Space?* London: RICS.
- Bosua, R., Gloet, M., Kurnia, S., Mendoza, A., & Yong, J. (2012). *Telework, productivity and wellbeing*. *Institute for a Broadband-Enabled Society*.
- Brenner, P. and Cornell, P. (2004). The balance between privacy and collaboration in knowledge worker teams. *Proceedings of the Fourth International Symposium on Human Factors in Organizational Design and Management*, 29 May to 2 June, Stockholm, Sweden.
- Brown, L. R. (1998). Worldwatch Institute. *State of the World 1998*. Norton.
- Business Insider Nederland & VodafoneZiggo. (2019, February 25). *Zo creëer je een slimmere werkomgeving - net zoals VodafoneZiggo in het nieuwe, Utrechtse kantoor*. Business Insider. Retrieved 18 April 2022, from <https://stories.businessinsider.nl/zo-creeer-je-een-slimmere-werkomgeving-net-zoals-vodafoneziggo-in-het-nieuwe-utrechtse-kantoor-vodafone/index.html>

- CBS. (2020, December 18). Hoeveel mensen werken (nooit) thuis? - Nederland in cijfers 2020. Hoeveel mensen werken (nooit) thuis? - Nederland in cijfers 2020 | CBS. Retrieved 16 April 2022, from <https://longreads.cbs.nl/nederland-in-cijfers-2020/hoeveel-mensen-werken-nooit-thuis/>
- CBRE. (2021a). *Core Talks by CBRE*. Retrieved 14 December 2022, from <https://www.cbre.nl/nl-nl/core-talks>
- CBRE. (2021b). *The Next Normal: How Hybrid Work Is Transforming Real Estate*. [https://www.cbre.com/-/media/project/cbre/shared-site/insights/reports/the-next-normal-hybrid-work/hybrid-work\\_the-next-normal.pdf](https://www.cbre.com/-/media/project/cbre/shared-site/insights/reports/the-next-normal-hybrid-work/hybrid-work_the-next-normal.pdf)
- Centraal Planbureau. (2021). *Thuiswerken vóór, tijdens en ná de coronacrisis*. CPB. [https://www.cpb.nl/sites/default/files/omnidownload/CPB-Achtergronddocument-Thuiswerken-voor-tijdens-en-na-de-coronacrisis\\_1.pdf](https://www.cpb.nl/sites/default/files/omnidownload/CPB-Achtergronddocument-Thuiswerken-voor-tijdens-en-na-de-coronacrisis_1.pdf)
- Clifford Chance Amsterdam. (2021a, August 16). Facebook. <https://www.facebook.com/CliffordChanceAmsterdam/photos/4961407480552408>
- Clifford Chance Amsterdam. (2021b, September 7). Facebook. <https://www.facebook.com/CliffordChanceAmsterdam/photos/5031413113551844>
- Clifford Chance. (2022). Clifford Chance | About Us. Retrieved 13 March 2022, from [https://www.cliffordchance.com/about\\_us.html](https://www.cliffordchance.com/about_us.html)
- Coenen, M., & Kok, R. A. (2014). Workplace flexibility and new product development performance: The role of telework and flexible work schedules. *European Management Journal*, 32(4), 564–576. <https://doi.org/10.1016/j.emj.2013.12.003>
- Conradie, W. J., & De Klerk, J. J. (2019). To flex or not to flex? Flexible work arrangements amongst software developers in an emerging economy. *SA Journal of Human Resource Management*, 17, 1–12. <https://doi.org/10.4102/sajhrm.v17i0.1175>
- Cook, J., Mor, Y., & Santos, P. (2020). Three cases of hybridity in learning spaces: Towards a design for a Zone of Possibility. *British Journal of Educational Technology*, 51(4), 1155–1167. <https://doi.org/10.1111/bjet.12945>
- Daft, R. (2015). *Management* (12th ed.). Cengage Learning, Inc.
- De Jonge, H. (1996). *Toegevoegde waarde van concernhuisvesting*. NSC-Conference, 15 oktober 1996.
- De Klerk, J. J., Joubert, M., & Mosca, H. F. (2021). Is working from home the new workplace panacea? Lessons from the COVID-19 pandemic for the future world of work. *SA Journal of Industrial Psychology*, 47. <https://doi.org/10.4102/sajip.v47i0.1883>
- Deloitte. (2021, May 10). *The future of office space can create financial opportunities*. Deloitte Insights. Retrieved October 22 2021, van <https://www2.deloitte.com/us/en/insights/topics/strategy/future-of-office-space-post-covid.html>
- Du Prie. (2019, June 27). *Vodafoneziggo Central Office*. Retrieved 17 April 2022, from <https://www.duprie.nl/project/vodafoneziggo-central-office-utrecht/>

- Duffy, F. (2008) *Justifying place in a virtual world*. [online] DEGW. Available from: [http://www.degw.com/publications/FDuffy\\_Connected%20Real%20Estate.pdf](http://www.degw.com/publications/FDuffy_Connected%20Real%20Estate.pdf) [Accessed 23 May 2009].
- Duffy, F. (2003). *Buildings and Society*. Buildings and Society: Essays on the Social Development of the Built Environment. <https://doi.org/10.4324/9780203480755>
- Eddleston, K. A., & Mulki, J. (2017). *Toward understanding remote workers' management of work-family boundaries: The complexity of workplace embeddedness*. *Group & Organization Management*, 42(3), 346–387. <https://doi.org/10.1177/1059601115619548>
- Fortune. (2020). 2020 Fortune CEO Survey. [https://f.datasvr.com/fr1/720/77406/Fortune\\_500\\_CEOs\\_Survey\\_results.pdf](https://f.datasvr.com/fr1/720/77406/Fortune_500_CEOs_Survey_results.pdf)
- Gajendran, R. S., & Harrison, D. A. (2007). The good, the bad and the unknown about telecommuting: Meta-analysis of psychological mediators and individual consequences. *Journal of Applied Psychology*, 92(6), 1524–1541. <https://doi.org/10.1037/0021-9010.92.6.1524>
- Galanti, T., Guidetti, G., Mazzei, E., Zappalà, S., & Toscano, F. (2021). Work From Home During the COVID-19 Outbreak. *Journal of Occupational & Environmental Medicine*, 63(7), e426–e432. <https://doi.org/10.1097/jom.0000000000002236>
- Gensler. (2005). *These Four Walls: The Real British Office*. London: Gensler.
- Gillen, N. (2021, March 26). *Managing Workplace Experience: Lessons from Retail*. (No. 41) [Podcast]. What's next in Corporate Real Estate. Accessed on December 10 2020, from <https://www.cushmanwakefield.com/en/insights/managing-workplace-experience-lessons-from-retail-podcast>
- Achternaam Host, Initialen. (Host). (jaar, dag maand). Titel aflevering (Nr. Nummer aflevering) [Podcastaflevering]. In Naam Podcast. Productiemaatschappij. Geraadpleegd op dag maand jaar, van URL**
- Grant, A. (Host). (2022, June 7). The Dos and Don'ts Of Returning To The Office [Audio podcast episode]. In *WorkLife with Adam Grant*. TED. Accessed on June 9 2022, from <https://open.spotify.com/episode/5ush5jMU78uHVzEYcdJWAy?si=bb3d55d3581049a5>
- Hammill, G. (2005). *Mixing and Managing Four Generations of Employees*. FDU Magazine. Retrieved 10 January 2022, from <https://portal.fdu.edu/newspubs/magazine/05ws/generations.htm>
- Hardy, B., Limited, D. L., (2008) Great Britain. Office of Government Commerce, DEGW London Limited, & Great Britain. Office of Government Commerce. (2008). *Working Beyond Walls*. Office of Government Commerce.
- Harris, R. (2012). *Reflections on the modern office*. Ramidus Consulting Limited. [https://www.researchgate.net/publication/330713205\\_Reflections\\_on\\_the\\_modern\\_office](https://www.researchgate.net/publication/330713205_Reflections_on_the_modern_office)
- Haynes, B. P. (2005). Workplace connectivity: a study of its impact on self-assessed productivity. *Journal of Corporate Real Estate*.
- Haynes, B. P., Nunnington, N., & Eccles, T. (2017). *Corporate Real Estate Asset Management* (2nd ed.). Taylor & Francis.

- Heywood, C., & Arkesteijn, M. (2018). Analysing fourteen graphical representations of corporate real estate alignment models. *Journal of Corporate Real Estate*, 20(1), 16–40. <https://doi.org/10.1108/jcre-02-2017-0005>
- Hofkamp, G., van Meel, J., van Meel, J., & Thoolen, F. (2013). *De WerkplekWijzer*. Center for People and Buildings.
- Hofstede Insights. (2021, June 22). *Compare countries*. Retrieved 20 November 2022, from <https://www.hofstede-insights.com/product/compare-countries/>
- JLL. (2020). *Reimagining Human Experience*. JLL Research. <https://www.us.jll.com/content/dam/jll-com/documents/pdf/research/jll-reimagining-human-experience-11-2020.pdf>
- Johnson, G., Scholes, K., & Whittington, R. (2008). *Exploring Corporate Strategy*. Prentice-Hall.
- Karjalainen, S. (2011). Thermal comfort and gender: a literature review. *Indoor Air*, 22(2), 96–109. <https://doi.org/10.1111/j.1600-0668.2011.00747.x>
- Kazekami, S. (2020). Mechanisms to improve labour productivity by performing telework. *Telecommunications Policy*, 44(2), 1–15. <https://doi.org/10.1016/j.telpol.2019.101868>
- Khodakarami, N., & Dirani, K. (2020). Drivers of employee engagement: Differences by work area and gender. *Industrial and Commercial Training*, 52(1), 81–91. <https://doi.org/10.1108/ICT-06-2019-0060>
- Kim, J., De Dear, R., Cândido, C., Zhang, H., & Arens, E. (2013). Gender differences in office occupant perception of indoor environmental quality (IEQ). *Building and Environment*, 70, 245–256. <https://doi.org/10.1016/j.buildenv.2013.08.022>
- Kraut, R., Fussell, S., Brennan, S. and Siegel, J. (2002), “*Understanding effects of proximity on collaboration: implications for technologies to support remote collaborative work*”, Hinds, P. and Kiesler, S. (Eds), *Distributed Work*, MIT Press, Cambridge, MA, pp. 137-162.
- Kuhn, T. S., University of Chicago. Press, Dewey, J., & Neurath, O. (1970). *The Structure of Scientific Revolutions*. Amsterdam University Press.
- Lee, A. (2018). *An exploratory case study of how remote employees experience workplace engagement*. PhD dissertations. Walden University. Retrieved from <https://scholarworks.waldenu.edu/cgi/viewcontent.cgi?article=6848&context=dissertations>
- Lee, H., Shin, B., & Higa, K. (2007). *Telework vs. central work: A comparative view of knowledge accessibility*. *Decision Support Systems*, 43(3), 687-700.
- Lufkin, B. (2021, August 11). *The case against hybrid work*. BBC Worklife. Retrieved 10 June 2022, from <https://www.bbc.com/worklife/article/20210806-the-case-against-hybrid-work>
- Mawson, A. (2002). *The Workplace and its Impact on Productivity*. Advanced Workplace Associates.
- Mache, S., Servaty, R., & Harth, V. (2020). Flexible work arrangements in open workspaces and relations to occupational stress need for recovery and psychological detachment from work. *Journal of Occupational Medicine and Toxicology*, 15(5), 1–11. <https://doi.org/10.1186/s12995-020-00258-z>

- McKinsey & Company. (2021, March 1). *Reimagining the post-pandemic workforce*. McKinsey & Company. Retrieved 22 October 2021, from <https://www.mckinsey.com/business-functions/people-and-organizational-performance/our-insights/reimagining-the-postpandemic-workforce>
- McNaughton, D., Rackensperger, T., Dorn, D., & Wilson, N. (2014). 'Home is at work and work is at home': Telework and individuals who use augmentative and alternative communication. *Work*, 48(1), 117–126. <https://doi.org/10.3233/WOR-141860>
- Meijel, L., & Bouma, T. (2013). *Kantoorgebouwen in Nederland 1945-2015: Cultuurhistorische en typologische quickscan*.
- Ministerie van Infrastructuur en Waterstaat. (2021, July 19). Onderzoek wijst uit: thuiswerken is een blijvertje. Nieuwsbericht | Rijksoverheid.nl. Retrieved 16 April 2022, from <https://www.rijksoverheid.nl/actueel/nieuws/2021/07/14/onderzoek-wijst-uit-thuiswerken-is-een-blijvertje>
- Moran, J. W., & Brightman, B. K. (2001). Leading organizational change. *Career Development International*, 6(2), 111–119. <https://doi.org/10.1108/13620430110383438>
- Morgan Lovell. (2021, August 6). *The Evolution of Office Design*. Retrieved 24 November 2021, from <https://www.morganlovell.co.uk/the-evolution-of-office-design>
- Nakrošienė, A., Bučiūnienė, I. and Goštautaitė, B. (2019), "Working from home: characteristics and outcomes of telework", *International Journal of Manpower*, Vol. 40 No. 1, pp. 87-101.
- Nederlandse Politie. (2020, May). *Jaarverantwoording Politie 2019*. <https://www.politie.nl/binaries/content/assets/politie/onderwerpen/jaarverantwoording/2019/infographic-politiecijfers-2019.pdf>
- Nederlandse Politie. (2021a, April). *Jaarverantwoording Politie 2020*. <https://www.politie.nl/binaries/content/assets/politie/onderwerpen/jaarverantwoording/2020/jaarverantwoording-politie-2020-inclusief-accountantsverklaring>
- Nederlandse Politie. (2021b, May 20). *Geschiedenis Nederlandse politie*. politie.nl. Retrieved 13 March 2022, from <https://www.politie.nl/informatie/geschiedenis-nederlandse-politie.html>
- Nederlandse Politie. (2021c, May 20). *Organisatiestructuur Nederlandse politie*. politie.nl. Retrieved 13 May 2022, from <https://www.politie.nl/informatie/organisatiestructuur-nederlandse-politie.html#:~:text=De%20missie%20van%20de%20politie>,
- Nederlandse Politie. (2021d, December 28). *HUB50, van en voor de politie*. politie.nl. Retrieved 13 February 2022, from <https://www.politie.nl/informatie/hub50-van-en-voor-de-politie.html>
- Nourse, H., & Roulac, S. (1993). Linking Real Estate Decisions to Corporate Strategy. *Journal of Real Estate Research*, 8(4), 475–494. <https://doi.org/10.1080/10835547.1993.12090723>
- Olson, R. K. (2002). *Dyslexia: nature and nurture*. *Dyslexia*, 8(3), 143–159. <https://doi.org/10.1002/dys.228>
- Oseland, N. (2013). *Personality and Preferences for Interaction*. Workplace Unlimited. <https://workplaceunlimited.com/Personality%20and%20Interaction%20v1.1.pdf>

- Pataki-Bittó, F., & Kapusy, K. (2021). Work environment transformation in the post-COVID-19 based on work values of the future workforce. *Journal of Corporate Real Estate*, 23(3), 151–169. <https://doi.org/10.1108/jcre-08-2020-0031>
- Perlow, L. A., & Kelly, E. L. (2014). Toward a model of work redesign for better work and better life. *Work and Occupations*, 41(1), 111–134. <https://doi.org/10.1177/0730888413516473>
- Plaskoff, J. (2017). Employee experience: The new human resource management approach. *Strategic HR Review*, 16(3), 136–141. <https://doi.org/10.1108/shr-12-2016-0108>
- PWC. (2020a). *The costs and benefits of working from home*. PricewaterhouseCoopers. <https://www.pwc.nl/nl/actueel-publicaties/assets/pdfs/pwc-the-costs-and-benefits-of-working-from-home.pdf>
- PWC. (2020b). *The costs and benefits of working from home, part II*. PricewaterhouseCoopers. <https://www.pwc.nl/nl/actueel-publicaties/assets/pdfs/pwc-working-from-home-part-II.pdf>
- Resnik, D. (2020). What Is Ethics in Research & Why Is It Important? - by David B. Resnik, J.D., Ph.D. National Institute of Environmental Health Sciences. Retrieved 24 April 2022, from <https://www.niehs.nih.gov/research/resources/bioethics/whatis/index.cfm>
- Roelofsen, P. (2002). The impact of office environments on employee performance: The design of the workplace as a strategy for productivity enhancement. *Journal of Facilities Management*, Vol. 1, No. 3, pp. 247-264.
- Rudolph, C. W., & Baltes, B. B. (2017). Age and health jointly moderate the influence of flexible arrangements on work engagement: Evidence from two empirical studies. *Journal of Occupational Health Psychology*, 22(1), 40–58. <https://doi.org/10.1037/a0040147>
- Saurin, R., & Ratcliffe, J. (2012). Using an adaptive scenarios approach to establish strategies for tomorrow's workplace. *Foresight*, 13(4), 46–63. <https://doi.org/10.1108/14636681111153968>
- Saurin, R., Ratcliffe, J., & Puybaraud, M. (2008). Tomorrow's workplace: a futures approach using prospective through scenarios. *Journal of Corporate Real Estate*, 10(4), 243–261. <https://doi.org/10.1108/14630010810925118>
- Schaufeli, W. B. (2013). What is engagement? In C. Truss, K. Alfes, R. Delbridge, A. Shantz, & E. Soane(Eds.), *Employee engagement in theory and practice* (pp. 15–36). London: Routledge.
- Scheffer, J. J., Singer, B. P., & Van Meerwijk, M. C. (2006). Enhancing the contribution of corporate real estate to corporate strategy. *Journal of Corporate Real Estate*, 8(4), 188–197. <https://doi.org/10.1108/14630010610714862>
- Singer, B. P., Bossink, B. A., & Vande Putte, H. J. (2007). Corporate real estate and competitive strategy. *Journal of Corporate Real Estate*, 9(1), 25–38. <https://doi.org/10.1108/14630010710742464>
- Sociaal en Cultureel Planbureau. (2021). *Thuis of terug naar kantoor Plus- en minpunten van thuiswerken voor het welbevinden van werknemers*. SCP. <https://www.scp.nl/publicaties/publicaties/2021/07/14/thuis-of-terug-naar-kantoor>
- Soebhan, S. (2020, November 16). Omgaan met thuiswerken en Corona-stress. LinkedIn. Retrieved 16 April 2022, from <https://www.linkedin.com/pulse/omgaan-met-thuiswerken-en-corona-stress-sabrina-soebhan/?originalSubdomain=nl>

- Stenerg, B., Mild, K. H., Sandstrom, M., Sundell, J., & Wall, S. (1993). A Prevalence Study Of The Sick Building Syndrome (SBS) And Facial Skin Symptoms In Office Workers. *Indoor Air*, 3(2), 71–81. <https://doi.org/10.1111/j.1600-0668.1993.t01-2-00002.x>
- Tagliaro, C. and Migliore, A. (2021), "Covid-working": what to keep and what to leave? Evidence from an Italian company", *Journal of Corporate Real Estate*, Vol. ahead-of-print No. ahead-of-print. <https://doi.org/10.1108/JCRE-10-2020-0053>
- Ten Brummelhuis, L. L., Bakker, A. B., Hetland, J., & Keulemans, L. (2012). Do new ways of working foster work engagement? *Psicothema*, 24(1), 113–120.
- Uddin, N., & Hossain, F. (2015). Evolution of Modern Management through Taylorism: An Adjustment of Scientific Management Comprising Behavioral Science. *Procedia Computer Science*, 62, 578–584. <https://doi.org/10.1016/j.procs.2015.08.537>
- Van Meel, J. (2000). *The European Office: office design and national context*. Rotterdam: 010 Publishers.
- Van Ree, H. J. (2002). The added value of office accommodation to organisational performance. *Work Study*, 51(7), 357–363. <https://doi.org/10.1108/00438020210449012>
- Van Wijngaarden, J. (2011). *The strategic value of the physical office workplace to multinational enterprises: an exploratory study into the relevance of national culture to employee productivity in developing regional or global workplace strategies*, Leeds: University of Leeds.
- Vander Elst, T., Verhoogen, R., & Godderis, L. (2020). Teleworking and Employee Well-Being in Corona Times. *Journal of Occupational & Environmental Medicine*, 62(12), e776–e777. <https://doi.org/10.1097/jom.0000000000002059>
- Vander Elst, T., Verhoogen, R., Servu, M., Van den Broeck, A., Baillien, E., & Godderis, L. (2017). Not the extent of telecommuting, but job characteristics as proximal predictors of work-related well-being. *Journal of Occupational and Environmental Medicine*, 59(10), 180–186. <https://doi.org/JOM.0000000000001132>
- Verbeek, G. (2020). *Apollolaan 171 AMSTERDAM*. Docplayer. Retrieved 1 February 2022, from <https://docplayer.nl/150998060-Apollolaan-171-amsterdam.html>
- VodafoneZiggo. (2017a). *Over ons: VodafoneZiggo*. Retrieved 10 April 2021, from <https://www.vodafoneziggo.nl/over-ons/vodafoneziggo>
- VodafoneZiggo. (2017b, November 6). *VodafoneZiggo opent centraal kantoor in hartje Utrecht*. Retrieved 13 April 2022, from <https://www.vodafoneziggo.nl/79/vodafoneziggo-opent-centraal-kantoor-in-hartje-utrecht>
- VodafoneZiggo. (2020, December). *VodafoneZiggo: Annual report*. LibertyGlobal. <https://www.libertyglobal.com/wp-content/uploads/2021/03/VodafoneZiggo-Q4-2020-Report.pdf>
- Warzel, C., & Petersen, A. H. (2021). *Out of Office*. Van Haren Publishing.
- Wells, M. M. (2000). Office clutter or meaningful personal displays: The role of office personalization in employee and organizational well-being. *Journal of Environmental Psychology*, 20(3), 239–255. <https://doi.org/10.1006/jevp.1999.0166>

- Wood, J., Oh, J., Park, J., & Kim, W. (2020). The relationship between work engagement and work-life balance in organizations: A review of the empirical research. *Human Resource Development Review*, 19(3), 240–262. <https://doi.org/10.1177/1534484320917560>
- WillisTowersWatson. (2020). *Flexible Work and Rewards Survey: 2021*. Design and Budget Priorities.
- World Economic Forum. (2021, 29 September). *Here's how employers can make work better post-COVID*. Retrieved 22 October 2021, from <https://www.weforum.org/agenda/2021/09/work-can-be-better-post-covid-heres-how/>
- Yin, R. K. & SAGE. (2003). *Case Study Research*. SAGE Publications.

## Appendix A: Informed Consent document

**Geïnformeerde toestemming**

Onderzoek: **De toekomstige werkplek: Hoe de kenmerken van de organisatie gereflecteerd worden in de hybride werkplek**  
 Onderzoeker: Oscar Nowak  
 Studie: MSc Management in the Built Environment  
 Organisatie: TU Delft, Faculteit Bouwkunde

	<i>ja</i>	<i>nee</i>
<b>Deelname onderzoek</b>		
Ik doe vrijwillig mee aan dit onderzoek, en ik begrijp dat ik kan weigeren vragen te beantwoorden en mij op elk moment kan terugtrekken uit de studie, zonder een reden op te hoeven geven.	<input type="checkbox"/>	<input type="checkbox"/>
Ik begrijp dat het interview wordt vastgelegd als geluid- of videoopname van een (online), met als doel transcriptie en analyse van de informatie. Na de analyse worden deze opnames verwijderd.	<input type="checkbox"/>	<input type="checkbox"/>
<b>Informatie verwerking</b>		
Ik geef toestemming om mijn rol (bv. architect, project manager) binnen het desbetreffende project te gebruiken in de scriptie. Alle andere persoonlijke informatie wordt geanonimiseerd.	<input type="checkbox"/>	<input type="checkbox"/>
Ik begrijp dat na het onderzoek de geanonimiseerde informatie gebruikt zal worden voor academische doeleinden (master scriptie) aan de Technische Universiteit Delft (tenzij bepaalde informatie vertrouwelijk is en dit wordt aangegeven door de geïnterviewde).	<input type="checkbox"/>	<input type="checkbox"/>
Ik geef toestemming om mijn antwoorden, ideeën of andere bijdrages anoniem te quoten in resulterende producten.	<input type="checkbox"/>	<input type="checkbox"/>
Ik geef toestemming dat de afgeronde afstudeerscriptie zal worden gepubliceerd in het openbare onderwijsdepot van de TU Delft, waarvan de geanonimiseerde transcripten hebben bijgedragen aan de resultaten van het onderzoek.	<input type="checkbox"/>	<input type="checkbox"/>

*Naam deelnemer*

*Handtekening deelnemer*

*Datum*

*Naam onderzoeker*

*Handtekening onderzoeker*

*Datum*

## Appendix B: Additional interview information document

### **De toekomstige werkplek**

Hoe de kenmerken van de organisatie worden gereflecteerd in de hybridewerkplek

Opleiding: MSc Management in the Built Environment  
 Organisatie: TU Delft, Faculteit Bouwkunde  
 Afstudeerorganisatie: Dev\_ real estate

#### *Het onderzoek*

Tijdens de pandemie bleek het thuiswerken voor de kennis- en dienstensector efficiënter en productiever dan van tevoren werd gedacht. Daarom is er nu van zowel de kant van de werknemer als van de werkgever een behoefte om meer thuiswerken toe te passen in de werkplek strategie. Deze combinatie van op kantoor én thuis (of elders) werken, wordt het hybride werken genoemd. Echter hebben veel organisaties geen beleid om van hun traditioneel kantoor een hybride werkplek te maken. Want hoe ziet de hybride werkplek specifiek voor jouw organisatie uit? Hoe kan deze nieuwe werkplek de doelen en de werkzaamheden van de organisatie en werknemer blijven ondersteunen? En hoe creëer ik genoeg draagvlak voor deze veranderingen?

Met dit actueel probleem als uitgangspunt onderzoek ik bij al toegepaste hybride werkplekken het verband tussen specifieke kenmerken van de organisatie en ontwerpkeuzes van de hybride werkplek. Dit doe ik door het transitieproces van de werkplek te onderzoeken vanuit verschillende invalshoeken, waaronder een interview met de architect, de projectmanager en belanghebbende vanuit de organisatie.

#### *Het interview*

Het interview duurt ongeveer één uur. Tijdens het interview wordt in vier stappen gezocht naar de connectie tussen de specifieke kenmerken van een bedrijf:

1. De kenmerken van de organisatie.
2. De uiting van deze kenmerken in het vastgoed.
3. De keuzes voor en tijdens de transitie naar de hybride werkplek.
4. De nieuwe werkplek.

De opnames van het interview worden na het transcriberen verwijderd. Behalve uw naam en uw rol tijdens het project wordt er geen persoonlijke of gevoelige informatie gebruikt in het eindproject. Voor het interview krijgt u de mogelijkheid om een 'Geinformeerde Toestemming' document te ondertekenen om uw privacy te waarborgen.

Voor vragen, onderzoeksgegevens of nadere informatie kunt u een e-mail sturen naar [oscamowak97@gmail.com](mailto:oscamowak97@gmail.com).